

DEENDAYAL PORT TRUST
(Erstwhile: KANDLA PORT TRUST)



Administrative Office
Post Box NO. 50
GANDHIDHAM (Kutch),
Gujarat: 370 201.
Fax: (02836) 220050
Ph.: (02836) 220038

www.deendayalport.gov.in

EG/WK/5202 (D)/ Part 1147

Date: 08/01/2022

To,
The Additional Secretary & Director (Environment), Govt. of Gujarat,
Forest & Environment Department,
Block No.14, 8th floor, New Sachivalaya,
Gandhinagar - 382 010
Kind Attn.: Dr. S. K. Lal, Scientist C, MoEF&CC, GoI, Bhopal.

Sub: CRZ Clearance for the Construction of Interchange cum Road Over Bridge (ROB) at LC-236 [Kutch salt junction] on N.H-141 to Nehru gate of Kandla port, Gandhidham, Kutch proposed by M/s Deendayal Port Trust - **Compliance of stipulated conditions mentioned in the CRZ recommendations reg.**

Ref.: 1) GCZMA CRZ recommendation vides Letter No- ENV-10-2017-74-E dated 21.01.2018
2) DPT Letter No. EG-WK-5202(D)-PART-34 dated 02.07.2021

Sir,

It is requested to kindly refer the above cited reference for the said subject.

In this connection, it is to state that, the Gujarat Coastal Zone Management Authority vide above referred letter dated 21.01.2018 had recommended the subject project of Deendayal Port Trust. Subsequently, the SEIAA, Gujarat had accorded the Environmental & CRZ Clearance vide EC Letter No. SEIAA/GUJ/EC&CRZ/8(b)/728/2020 dated 19.06.2020 for the subject project.

DPT had signed an MOU with M/s IPRCL vide Certificate no. IN-GJ9522335926842S dated 9/06/2020 wherein IPRCL was appointed as the Project Implementation Agency for the project (Copy of MoU attached as Annexure A of the EC&CRZ Compliance).

Accordingly, as directed under Specific Condition No. 17 mentioned in the CRZ Clearance letter dated 21.01.2018 i.e. A six monthly report on compliance of the conditions mentioned in this letter shall have to be furnished by the DPT on a regular basis to this Department and MoEF&CC, GoI, please find enclosed herewith compliance report of the stipulated conditions along with necessary annexure submitted by M/s IPRCL, for kind information & record please (Annexure I).

.....contd.

Further as per MoEF&CC, Notification S.O.5845 (E) dated 26.11.2018, stated that "In the said notification, in paragraph 10, in sub-paragraph (ii), for the words "soft copy" shall be substituted". Accordingly, we are submitting herewith soft copy of the same via e-mail.

This has the approval of the Chief Engineer, Deendayal Port Trust.

Thanking You.

Yours faithfully,

Superintending Engineer (PL) & EMC (I/c)
Deendayal Port Trust

Copy along with point wise compliance of stipulated conditions, to :

1) The Member Secretary,
State Level Environmental Impact Assessment Authority, Gujarat,
C/O, Gujarat Pollution Control Board
Sector- 10 A, Gandhinagar-382 010.
Email ID- seiaaguj@yahoo.com

2) Shri Prasoon Gargav,
Scientist E & Regional Director,
Central Pollution Control Board,
Parivesh Bhawan,
Opp. VMC Ward Office No.10, Subhanpura,
Vadodara - 390 023.
Email: prasoon.cpcb@nic.in

3) Smt. Urvashi Upadhyay,
Environment Engineer,
Unit Head, Kachchh ,
Gujarat Pollution Control Board,
Paryavaran Bhavan,
Sector 10A, Gandhinagar- 382 010.
Email-kut-uh-gpcb@gujarat.gov.in

4) The Regional Officer,
Gujarat Pollution Control Board,
Regional Office (East Kutch), Administrative Office Building,
Deendayal Port Trust, Gandhidham.
Email Id. ro-gpcb-kute@gujarat.gov.in

DEENDAYAL PORT TRUST
(Erstwhile: KANDLA PORT TRUST)



Administrative Office Bu
Post Box NO. 50
GANDHIDHAM (Kutch),
Gujarat: 370 201.
Fax: (02836) 220050
Ph.: (02836) 220038

www.deendayalport.gov.in

EG/WK/5202 (D)/ Part 1146

Date: 07/02/2022

To,
The Deputy Director General of Forest (Central),
Ministry of Environment, Forests & Climate Change,
Integrated Regional Office, Gandhinagar
Kendriya Paryavaran Bhavan
Link Road No.3, Ravi Shankar Nagar,
Bhopal- 462016(M.P.).
Email: rowz.bpl-mef@nic.in, ecompliance-guj@gov.in

Kind Attn.: Dr. Shri B. K. Thakur, IFS, Scientist C, MoEF&CC, GoI, Bhopal.

Sub: Environment & CRZ Clearance for the Construction of Interchange cum Road Over Bridge (ROB) at LC-236 [Kutch salt junction] on N.H-141 to Nehru gate of Kandla port, Gandhidham, Kutch proposed by M/s Deendayal Port Trust – **Compliance of stipulated Conditions mentioned in the Environmental & CRZ Clearance req.**

Ref.: 1) EC & CRZ Clearance accorded by the State Level Environment Impact Assessment Authority (SEIAA), Gujarat letter no. SEIAA/GUJ/EC&CRZ/8(b)/728/2020 dated 19.06.2020.
2) DPT letter no. EG-WK-5202(D)-PART-33 dated 02.07.2021

Sir,

It is requested to kindly refer above cited references for the said subject.

In this connection, it is to state that, the SEIAA, Gujarat had accorded Environmental & CRZ Clearance for the subject proposal vide above referred letter dated 19.06.2020.

DPT had signed an MOU with M/s IPRCL vide Certificate no. IN-GJ95223355926842S dated 9/06/2020 wherein IPRCL was appointed as the Project Implementation Agency for the project (Copy of MoU attached as Annexure A of the EC&CRZ Compliance).

Accordingly, please find enclosed herewith point-wise compliance report of the stipulated conditions mentioned in the EC & CRZ Clearance letter dated 19.06.2020 (**Annexure 1**) & Monitoring Report in Data Sheet (**Annexure 2**) (Period June to November, 2021) submitted by M/s IPRCL for kind information and record please.

This has the approval of the Chief Engineer, Deendayal Port Trust.

Thanking You.

Yours faithfully,

Superintending Engineer (PL) & EMC (I/c)
Deendayal Port Trust
.....Cont.....

Copy along with point wise compliance of stipulated conditions, to:

1) The Member Secretary,
State Level Environmental Impact Assessment Authority, Gujarat,
C/O, Gujarat Pollution Control Board
Sector- 10 A, Gandhinagar-382 010.
Email ID- seiaaguj@yahoo.com

2) Shri Prasoon Gargav,
Scientist E & Regional Director,
Central Pollution Control Board,
Parivesh Bhawan,
Opp. VMC Ward Office No.10, Subhanpura,
Vadodara - 390 023.
Email: prasoon.cpcb@nic.in

3) Smt. Urvashi Upadhyay,
Environment Engineer,
Unit Head, Kachchh,
Gujarat Pollution Control Board,
Paryavaran Bhavan,
Sector 10A, Gandhinagar- 382010.
Email-kut-uh-gpcb@gujarat.gov.in

4) The Regional Officer,
Gujarat Pollution Control Board,
Regional Office (East Kutch), Administrative Office Building,
Deendayal Port Trust, Gandhidham.
Email Id. ro-gpcb-kute@gujarat.gov.in

Annexure -I

Monthly Project Status Report

(To be submitted for each PPP and non-PPP projects by 10th of every month for the project's progress of previous month)

1	Port Name	Deendayal Port Trust		
2	Project Name	Construction of Interchange cum Road Over Bridge (ROB) at LC-236 (Kutch Salt Junction) on NH-141 in the State of Gujarat under EPC mode.		
3	Period of this report	October' 2021		
4	Project Mode	EPC Mode		Project Cost (Port's Scope)
5	Concessionaire/EPC	M/s Niroj-Patel JV, Gandhidham, Kutch, Gujarat has been appointed by M/s IPRL.	Project Cost (by PPP/Captive)	Rs.254.92 Cr. N.A.
6	Ministry's Approval	i) Project approved by the SFC on 24.04.2017 (SFC Meeting held on 16.01.2017) ii) Ministry vide OM dtd: 26.6.2018 directed to DPT to transfer the project to IPRL, accordingly Board of Deendayal Port vide R. No. 64, dtd: 07/08/2018 has transferred the project to IPRL, Mumbai IPRL on direct cost plus basis.		
7	Port's Nodal officer for project	Shri Srinivas Rao, SE (H), Deendayal Port Trust.		
8	Start Date of RFQ	N.A.	Completion Date of RFQ	N.A.
9	Start Date of RFP	02.11.2018	Completion Date of RFP	24.07.2019
10	LOI Date/LOA Date	25.02.2020	Date of Signing of Concession	23.03.2020
11	Award Date of Concession/EPC	23.03.2020	Start Date of Construction	01.10.2020
12	Target COD date	31.03.2023	Implementation time (as per DPR)	30 Months
13	Cumulative Project Progress achieved till date	Physical Progress (Port's Scope)	N.A.	Financial Progress (Port's Scope)
		Physical Progress (PPP/captive/EPC's Scope)	51.64%	Financial Progress (PPP/captive/EPC's Scope)
14	Delay in Overall Project, if any (Provide updated Annexure-A and Annexure-B with this report)	Shortfall in Physical Progress (Port's Scope)	N.A.	Shortfall in Financial Progress (Port's Scope)
			N.A.	N.A.
		Shortfall in Physical Progress (PPP/captive/EPC's Scope)	N.A.	Shortfall in Financial Progress (PPP/captive/EPC's Scope)
			N.A.	N.A.
15	Project Progress achieved in Last Month	Physical Progress (Port's Scope)	N.A.	Financial Progress (Port's Scope)
		Physical Progress (PPP/captive/EPC's Scope)	0.64%	Financial Progress (PPP/captive/EPC's Scope)
16	Main Accomplishments in the Last Month (Port's Scope)	1	Nil	
		2	Nil	
		3	Nil	
		4	Nil	
		5	Nil	
17	Main Accomplishments in the Last Month (PPP/captive/EPC's Scope)	1	PSC Girder Casting - 16 nos	
		2	RE Wall panel casting : 2121 Sqm.	
		3	Road work WMM: 2597 m / 13679 m	
		4	Road work DBM: 1880 m / 13679 m	
		5	PVD Ground improvement Work: 7568 Sqm/ 60000 Sqm	
18	Scope Change, if any	N.A.		
19	Schedule Change, if any	N.A.		
20	Cost Change, if any	N.A.		
21	Issues/impediments, if any	N.A.		
22	Issue pending, with any central Govt ministry, causing delay	N.A.		
23	Safety Performance	Number of Safe Man-hours	N.A.	
		Near Misses	N.A.	Last Time Incidents
		First Aid Cases	N.A.	Number of Fatalities
24	Employment Details	Direct Employment (Port's Scope)	N.A.	Direct Employment (Port's Scope)
		Direct Employment (PPP/captive/EPC's Scope)	N.A.	Direct Employment (PPP/captive/EPC's Scope)

[Signature] 6.12.2021

Page 1 of 4
Jt. GENERAL MANAGER,
IPRL/GANDHIDHAM

25	This Report Prepared by	Shri Srinivas Rao, SE (H), Deendayal Port Trust.				
26	This Report Reviewed by	Shri Srinivas Rao, SE (H), kphdivision@gmail.com				

 8/12/2021

Signature (approving authority)

Jt. GENERAL MANAGER. (P)
IPRCL/ GANDHIDHAM

Note, Annexure-A and Annexure-B shall be provided along with this report

Project Milestones (Port's Scope)

(All milestones to be planned and indicated below from Ministry's approval date to COD of project)

Month	Milestone Description	Target/Planned completion date	Actual Completion Date	Reason for Delay, if any
		A	B	C
October 2020 to March 2021	Project Milestone I (10%)	31.03.2021	31.01.2021	N.A.
April 2021 to September 2021	Project Milestone II (20%)	30.09.2021	28.02.2021	N.A.
October 2021 to March 2022	Project Milestone III (45%)	31.03.2022	-	-
April 2022 to September 2022	Project Milestone IV (70%)	30.09.2022	-	-
October 2022 to March 2023	Project Milestone V (100%)	31.03.2023	-	-

Notes:

1. Column 'A' above should be filled only once based on original project schedule
2. Only Column 'B' to be updated on monthly basis for respective row
3. Detailed reasoning to be provided in column 'C'

 6.12.2021
 Jt. GENERAL MANAGER. (P)
 IPRL/ GANDHIDHAM

Project Milestones (PPP/Captive/EPC's Scope)

(All milestones to be planned and indicated below from the Ministry's approval date to COD of project)

Month	Milestone Description	Target/Planned completion date	Actual Completion Date	Reason for Delay, if any
		A	B	C
October 2020 to March 2021	Project Milestone I (10%)	31.03.2021	31.01.2021	N.A.
April 2021 to September 2021	Project Milestone II (20%)	30.09.2021	28.02.2021	N.A.
October 2021 to March 2022	Project Milestone III (45%)	31.03.2022	-	-
April 2022 to September 2022	Project Milestone IV (70%)	30.09.2022	-	-
October 2022 to March 2023	Project Milestone V (100%)	31.03.2023	-	-

Notes:

1. Column 'A' above should be filled only once based on original project schedule
2. Only Column 'B' to be updated on monthly basis for respective row
3. Detailed reasoning to be provided in column 'C'

 6-12-21
Jt. GENERAL MANAGER, (P)
IPRCL/ GANDHIDHAM



इंडियन पोर्ट रेल एंड रोपवे कॉर्पोरेशन लिमिटेड
(पूर्व नाम इंडियन पोर्ट रेल कॉर्पोरेशन लिमिटेड)
(पोत परिवहन मंत्रालय भारत सरकार के अधीन संयुक्त उद्यम)
Indian Port Rail & Ropeway Corporation Ltd.
(formerly known as Indian Port Rail Corporation Ltd.)

(A JV Company under Ministry of Ports, Shipping and Waterways, Government of India)
CIN No: U60300DL2015PLC282703



No. IPRCL/GIMB/Projects/DPT/ROB/6004/170

Date: 18.01.2022

To,
Superintending Engineer (H)
Deendayal Port Trust,
Gandhidham

Sub: Construction of Interchange cum Road over Bridge (ROB) at LC-236(Kutch Salt Junction) on NH-141 (Phase-1) in the state of Gujarat under EPC Mode.
- **"Six Monthly compliance report of conditions stipulated in Environmental & CRZ Clearance & Monitoring Report in Data sheet". Reg.**

Ref: 1. DPT Letter no. HW/WK/1008-V/105 dated 05.04.2020
2. IPRCL Letter no. IPRCL/Mumbai/DPT/ROB/03 dated 25.08.2020

Sir,

With reference to the above subject, it is to inform that Six Monthly compliance report of conditions stipulated in Environmental & CRZ Clearance & Monitoring Report in Data sheet as per condition stipulated in EC and CRZ clearance issued by SEIAA, Gujarat vide Letter No. SEIAA/GUJ/EC&CRZ/8(b)/728/2020 dated 19th June 2020 is attached as Annexure-1,2 & 3.

This is for your information and necessary action please.

Thanking you.

Yours Sincerely,

(S. Revanasiddappa)
Joint General Manager (P)
Gandhidham

CC: 1) CGM(P)/SW/Mumbai for information please.



Subject: Point wise compliance of stipulated conditions of "**Environmental & CRZ Clearance for the Construction of Interchange cum Road Over Bridge (ROB) at LC-236 [Kutch Salt Junction] on NH-141 to Nehru gate of Kandla port, Gandhidham, Kutch by M/s Deendayal Port Trust**".

Reference: EC & CRZ Clearance issued by SEIAA, Gujarat vide EC Letter No. SEIAA/GUJ/EC&CRZ/8(b)/728/2020 dated 19th June, 2020

DPT had signed an MOU with M/s IPRCL vide Certificate no. IN-GJ95223355926842S dated 9/06/2020 wherein it was IPRCL was appointed as the Project Implementation Agency for the project. (**Copy of MoU attached as Annexure A**).

A. 1 Specific Conditions: -

Sl. No.	Stipulated Conditions	Compliance
1.	All the provisions of CRZ Notification -2011 shall be strictly adhered to and no activity in contradiction to the provisions of CRZ Notification - 2011 shall be carried by the project proponent.	IPRRCL (Project Implementation Agency) has submitted that it will adhere to all the provisions of CRZ Notification -2011. Point-wise compliance to the CRZ recommendation issued by the GCZMA is attached as Annexure I .
2.	The project proponent shall strictly ensure that no creeks or flow of water are blocked due to any activity at the project site.	IPRRCL (Project Implementation Agency) has submitted that it has been ensuring that no creeks or flow of water are being blocked due to any activity at the project site and the pipe culverts will be constructed at required location in creek for free flow of water.
3.	The project proponent shall obtain all other necessary clearances / permissions from concerned authorities / agencies required for undertaking the proposed project.	The Consent to Establish (CTE) from the GPCB had already been obtained vide CTE No. 89489 granted by the GPCB vide letter no. PC/CCA-KUTCH 1449/GPCB ID 56869 dated 03/10/2017 attached as Copy Annexure II . Copy of approved GAD enclosed as Annexure III .
4.	It will be the responsibility of the project proponent to obtain prior clearances/approval & ensure compliances under all other relevant Acts/ Rules/ Regulations/ Guidelines/ instructions' Court orders/ Tribunal orders as applicable to this project as per the prescribed time limits. All the Terms & Conditions Stipulated in the clearances/ approvals shall be strictly adhered to.	The Consent to Establish (CTE) from the GPCB had already been obtained vide CTE No. 89489 granted by the GPCB vide letter no. PC/CCA-KUTCH 1449/GPCB ID 56869 dated 03/10/2017 attached as Copy Annexure II . Copy of approved GAD enclosed as Annexure III . IPRCL has submitted that the Terms & Conditions Stipulated in the clearances/ approvals is being strictly adhered to.
5.	The approval of competent authority shall be obtained for	IPRCL has submitted that the structural design has been done by

Jt. GENERAL MANAGER (P)
IPRCL/GANDHIDHAM

	structural safety of the bridge due to earthquake, including protection measures from lightening etc. Copy of approved structural drawings & certificate from the concerned competent authority shall be submitted to SEAC/ SEIAA before commencement of work for the project.	design consultant i.e. M/s Nivedita Consultants and checked by proof consultant i.e. M/s Nitya Nayra Civil Solutions Pvt. Ltd. and safety consultant M/s Forgiving Roads LLP. Further IPRCL has conducted a third-party independent design audit which was done by Indian Institute of Technology (BHU) Varanasi for the design of bridges and structure with a span of 15.0m or more. The audit reports vide doc number-KUT-SUP STR-ROB-RLY-CH"0+639.1-DN-01 is attached as Annexure IV .
6.	Structural design of the project shall strictly adhere to the seismic zone norms for earthquake resistant structures.	IPRCL has submitted that the Structural design of the project is done by design consultant i.e. M/s Nivedita Consultants considering seismic zone-V for earthquake resistant structure.
7.	Traffic study shall be carried out periodically to develop & implement the scheme to ensure smooth flow of traffic from & to the proposed ROB.	IPRCL has submitted that the Traffic diversion plan has been prepared considering smooth flow of traffic and same is approved by MORTH vide letter no. RW/GNR/NH/HA/NOC/03/782 dated 14.10.2020. The approval letter is attached as Annexure V .
8.	DDPT shall ensure that there shall not be any blockage of creek and free-flow of water is maintained.	IPRCL (Project Implementation Agency) has submitted that no creeks or flow of water are being blocked during execution of the project work.
9.	The DDPT shall construct settling ponds and the installation of the oil receptor to prevent the entry of the surface run-off from fuel and other contaminants into the wells and other surface water bodies along the corridor.	IPRCL has submitted that there are no wells in the project area and it will be observed that there is no spillage of fuel at project area.
10.	No vehicles or equipment shall be parked or refuelled near the water-body, so as to avoid contamination from fuel and lubricants.	IPRCL has submitted that Vehicles and equipments are parked and refuelled at the site office area, and there is no sweet water body near the site office.
11.	The DDPT shall implement all the suggestions/ recommendations given in the EIA report by their consultant M/S Mantec Consultant Pvt Ltd.	IPRCL has submitted that all the suggestions/ recommendations given in the EIA report by consultant are being implemented.



 Jt. GENERAL MANAGER. (P)
 IPRCL/GANDHIDHAM

A.2 CONSTRUCTION PHASE:

12.	The traffic diversion plan shall be finalized in consultation with CE (NH), Gujarat & RO, Gandhinagar and get approved from the concerned competent authority before starting the construction activity for the proposed ROB. Copy of the same shall be submitted to SEAC/ SEIAA.	IPRCL has submitted that the Traffic diversion plan was approved by National highway Gujarat & RO Gandhinagar vide Letter dated: RW/GNR/NH/HA/NOC/03/782 dated 14.10.2020. The same is attached as Annexure V .
13.	DDPT shall ensure that adequate culvert/passages are provided during construction of road and there shall be no obstruction of free flow of water.	IPRCL has submitted that a total of 15 culverts have been provided by the design consultant and it is being ensured that there is no obstruction to free flow of water. (Copy of GAD of Culverts attached as Annexure VI).
14.	Hot-mix plants/Concrete mix plants shall be located and operated in such a way that there shall be no Air Pollution.	IPRCL has submitted that only GPCB approved Hot-mix plants/Concrete mix plants is being allowed to operate for the project. IPRCL obtained the CCA from GPCB for the HMP vide its letter no. 415000 dated 15/06/2017. (Copy of CCA attached as Annexure VII).
15.	The DDPT shall ensure that the quarry works, from which they will purchase raw materials, shall conform to the norms and having necessary clearances from the respective authorities.	IPRCL has submitted that the quarry works, from which raw materials are purchased, conforms to the norms and has necessary clearances from the respective authorities.
16.	The DDPT — shall make MOU with the raw material supplier quarry/hot mix plants etc., in such a way that they will comply with all the terms and conditions mentioned in the CCA/NOC issued by the Gujarat Pollution Control Board.	IPRCL has submitted that the raw materials are being purchased by the contractors directly hence M.O.U by DPT with supplier is not required. However, conditions mentioned in NOC by GPCB are being complied with.
17.	Fresh water requirement during the construction phase shall be 95.0 KL/day and it shall be met through the water tankers for water supply from Gujarat water supply and sewerage board. No ground water shall be tapped during the construction phase.	IPRCL has submitted that the fresh water requirement during the construction phase is being met with Private Tanker Supplying agency. It is ensured that no ground water is being tapped during the construction phase.

Jt. GENERAL MANAGER (P)
IPRCL/GANDHIDHAM

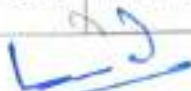
18.	There shall no discharge of any kind of wastewater/sewage/effluent into the creek/sea or in the CRZ areas.	IPRCL has submitted that there is no discharge of any kind of wastewater/sewage/ effluent into the creek/sea or in the CRZ areas.
19.	Sewage generated during the construction phase shall be treated in septic tanks connected to water recycling chambers of adequate capacity & comprising of adequate treatment facilities as proposed. Treated water ~ 20.0 KL/day conforming to GPCB norms shall be used for greenbelt development and dust suppression.	IPRCL has submitted that Sewage generated during the construction phase is being treated in septic tank.
20.	No construction debris and / or any other type of waste / wastewater shall be disposed of in CRZ areas.	IPRCL has submitted that no construction debris and / or any other type of waste / wastewater are being disposed of in CRZ areas.
21.	Construction materials and debris shall be properly stored and handled to avoid negative impacts such as air pollution and public nuisances by blocking the roads and public passages. The debris shall be removed from the construction site immediately after the construction is over.	IPRCL has submitted that the generated debris is being removed from the site regularly to avoid any blocking the roads and public passages.
22.	It shall be ensured that there is no adverse impact on the drainage of the area due to the construction activities.	IPRCL (Executive agency) has submitted that there is no adverse impact on the drainage of the area due to the construction activities.
23.	Solid waste likely to be generated from construction site and labour camps during construction phase will be collected and disposed of as per the Solid Waste Management Rules – 2016.	IPRCL (Executive agency) has submitted that solid waste generated from construction site & labor camp is being disposed off as per solid waste management Rules-2016 by IPRCL.
24.	The construction camps shall be kept outside the CRZ areas and the construction labour shall be provided with adequate amenities like drinking water, fuel, sanitation, etc. to ensure that the existing environmental condition is not deteriorated by them.	IPRCL has submitted that it has provided adequate amenities like drinking water, fuel, sanitation, etc. to the construction laborers.
25.	Ready Mix Concrete should be used so far as possible. Water demand during construction should be reduced by use of curing agents, plasticizers and other best practices.	IPRCL has submitted that the ready mix concrete plant has been provided in its premises to reduce usage of water and water usage is being reduced by using STP treated water.

 Jt. GENERAL MANAGER. (P)
 IPRCL/GANDHI

A.3 OPERATION PHASE:

A.3.1 WATER

26.	Total water requirement during the operation phase for dust suppression & greenbelt development shall be 15.0 KL/day which shall be met through water supply system of Gujarat Water Supply and Sewerage Board.	IPRCL has submitted that the roads shall be constructed with flexible pavement and thus no dust suppression is required. However, water required for green belt area will be purchased from GWSSB.
27.	No bore well shall be constructed and existing bore well/s, if any, shall be either sealed or converted into the recharge well.	IPRCL has submitted that no bore-well is being constructed in the project area.
28.	The storm water from the bridge shall be properly channelized. Provisions shall be made for ground water recharge through rain water harvesting as per the details submitted. Before recharging the run off pre-treatment must be done to remove suspended matter.	IPRCL has submitted that this segment is not applicable as the project site area has saline water and impervious soil strata.
29.	Rainwater harvesting system shall be properly maintained & kept functional and periodical cleaning of the same shall be undertaken specifically including the period before onset of the monsoon.	IPRCL has submitted that this segment is not applicable as the project site area has saline water and impervious soil strata.
30.	The water meter shall be installed and records of monthly water consumption shall be maintained regularly.	IPRCL has submitted that this segment is not applicable.

A.3.2 AIR

31.	D. G. sets (3 x 500 KVA) proposed as backup power shall be of enclosed type and conform to prescribe standards under EPA rules. Necessary acoustic enclosures shall be provided at diesel generator set to mitigate the impact of noise.	IPRCL has submitted that D.G set is conforming to emission limit prescribed under EPA rules is provided.
32.	The gaseous emissions from the D.G. Sets shall conform to the emission limits prescribed under EPA rules as amended from time to time. At no time, the emission levels shall go beyond the	IPRCL has submitted that D.G set conforming to emission limit prescribed under EPA rules will be provided if required.

Jt. GENERAL MANAGER (P)
IPRCL/GANDHIDHAM

	stipulated standards.	
33.	The stack height of the D.G. sets shall be equal to the height needed for the combined capacity of all proposed D.G. sets.	IPRCL has submitted that its compliance shall be ensured.

A. 3.3 SOLID / HAZARDOUS WASTE

34.	The project must strictly comply with the rules and regulations with regards to handling and disposal of hazardous waste in accordance with the Hazardous Waste (Management, Handling and Transboundary) Rules 2008. Authorization from the GPCB must be obtained for collection / treatment / storage / disposal of hazardous wastes.	IPRCL has submitted that no hazardous waste is being generated during the project construction.
35.	Discarded Containers, /Carboys and Used/ Lubricating Oil shall be sold to the authorized recyclers.	IPRCL has submitted that Container/ Carboys and Used/Lubricating oil is being sold to the authorized recyclers only.
36.	The project proponent shall have to ensure that plastic waste is segregated and disposed of by selling it to the registered recyclers.	IPRCL has submitted that Plastic waste is being disposed of by selling it to the registered recyclers, if needed.
37.	Necessary arrangements shall be made for safe disposal of municipal solid wastes as per the provisions of the Solid Wastes Management Rules, 2016 as amended from time to time and solid wastes shall not be released in marine water / coastal area in any case.	IPRCL has submitted that solid wastes are being disposed in compliance to the Solid Waste Management rules- 2016 and shall not be released in marine water/ coastal area in any case.

A. 3.4 SAFETY:

38.	Dedicated power back up system shall be provided in the case of power failure & emergency of fire water pumps.	IPRCL has submitted that dedicated power back up system will be provided if required.
39.	Compulsory training, for the first aid and firefighting along with regular mock drill shall be imparted to the Security personnel and D.G. Operator.	IPRCL has submitted that training for the first aid shall be imparted to the security person and D.G Operator.
40.	First Aid Boxes shall be provided in adequate quantity at strategic locations.	IPRCL has submitted that First aid box has been provided at site office.

 Jt. GENERAL MANAGER. (P)
 IPRCL/ GANDHIDHAM

41. Transportation of materials shall be as per the Motor Vehicle Act & Rules.	IPRCL has submitted that Transportation of material is being done as per Motor Vehicle Act & Rules.
--	---

A. 3.5 CLEANER PRODUCTION, ENERGY CONSERVATION AND WASTE MINIMISATION:

42. Energy conservation measures like maximum use of natural light, wind & ventilation through architectural design, solar based LED lights in landscaped and drive way areas, LED/CFL light for walk way areas etc. shall be provided as proposed.	IPRCL has submitted that LED lights have been provided in all the offices & site for energy conservation.
---	---

A. 3.6 PARKING / TRAFFIC CONGESTION:

43. No public space shall be used or blocked for the parking and the trained staff shall be deployed to guide the visitors for parking and helping the senior citizens and physically challenged people.	IPRCL has submitted that parking of equipment's is being done at site office area and the visitors are guided by trained staff whenever required.
--	---

A. 3.7 GREEN BELT

44. Green belt area of 25,000 m ² shall be developed as proposed. Plantation along the bridge and road shall be done with native varieties.	IPRCL has submitted that green belt area is being developed as per the tender provision.
--	--

B. GENERAL CONDITIONS:

1. PRE -CONSTRUCTION AND CONSTRUCTION

45. Environment Management Cell shall be formed, which shall supervise and monitor the environment related aspects of the project during construction and operational phases in addition to observance of Gujarat Building and other Construction Workers' (Regulation of Employment & Conditions of Service) Rules 2003.	All the environment related aspects of the project during construction and operational phase are being supervised by Project Implementation Agency. DPT has signed an MOU with M/s IPRCL vide Certificate no. IN-GJ95223355926842S dated 9/06/2020 wherein it was IPRCL was appointed as the Project Implementation Agency for the project.
46. Prior permission from the	IPRCL has submitted that whenever

 JE. GENERAL MANAGER. (P)
 IPRCL/GANDHIDHAM

	competent authority shall be obtained for cutting of the existing trees before site preparation work is commenced.	necessity arises, permission from the concerned authority shall be obtained.
47.	Water demand during construction shall be reduced by use of curing agents, super plasticizers and other best construction practices.	IPRCL has submitted that, curing agents and super plasticizers are being used for construction work as and when required to reduce the water consumption.
48.	Temporary wind shield shall be done to prevent dust emission spreading outside the project premises. Barricade of adequate height shall be provided on the periphery of the construction site with adequate signages, Individual building within the project site shall also be provided with barricades.	IPRCL has submitted that, there is no building with in the project site area. However temporary wind shield shall be provided at required location.
49.	Regular water sprinkling shall be done in vulnerable areas for controlling fugitive emission.	IPRCL has submitted that, water sprinkling is being done in vulnerable area on need basis.
50.	The roads inside the project area and roads connected to the main road shall be paved or shall be water sprinkled to avoid the fugitive emissions during vehicular movement.	IPRCL has submitted that, water sprinkling is being done in diversion road to avoid the fugitive emissions during vehicular movement.
51.	Material shall be covered during transportation to avoid the fugitive emission.	IPRCL has submitted that, material is being covered during transportation for particular items.
52.	Uniform piling and proper storage of sand to avoid fugitive emissions shall be ensured.	IPRCL has submitted that, sand is stored properly to avoid fugitive emission.
53.	Structural design of the project shall strictly adhere to the seismic zone norms for earthquake resistant structures.	IPRCL has submitted that the Structural design done by design consultant i.e. M/s Nivedita Consultants and checked by proof consultant i.e. M/s Nitya Nayra Civil Solutions Pvt. Ltd. and safety consultant M/s Forgiving Roads LLP. A third-party independent design audit was done by Indian Institute of Technology (BHU) Varanasi for the design of bridges and structure with a span of 15.0m or more. The audit reports vide doc number-KUT-SUP STR-ROB-RLY-CH"0+639.1-

 Jt. GENERAL MANAGER, (P)
 IPRCL/GANDHIDHAM

		DN-01 is attached as Annexure IV.
54.	The planning, designs and construction of all buildings shall be such as to ensure safety from fire.	IPRCL has submitted that this section is not applicable as this is a road project.
55.	The project proponent shall ensure maximum employment to the local people.	IPRCL has submitted that the local people are employed considering the nature of work.
56.	All required sanitary and hygienic measures shall be provided before starting the construction activities and to be maintained throughout the construction phase.	IPRCL has submitted that all required sanitary and hygienic measures have been provided before starting the construction activities.
57.	Provision shall be made for housing of construction labour within the site with all necessary infrastructure and facilities such as fuel for cooking, mobile toilets, mobile STP, safe drinking water, medical healthcare, crèches, electricity & ventilation, canteen, rest rooms, safe disposal system for garbage, first aid, medical and emergency facilities etc. to ensure that they do no ruin the existing environmental condition. The housing may be in the form of temporary structures to be removed after completion of the project.	IPRCL has submitted that all temporary houses have been constructed for labor in the site area with necessary infrastructure & facilities.
58.	Adequate personal protective equipments shall be provided to the construction workers to ensure their safety and the project proponent shall ensure its usage by the labourers.	IPRCL has submitted that PPE kits have been provided to the workers for safety.
59.	First Aid Box shall be made readily available in adequate quantity at all the times.	IPRCL has submitted that First aid box has been provided at site office.
60.	First Aid Box shall be made readily available in adequate quantity at all the times.	IPRCL has submitted that training has been given to all workers for safety by tool box talk at site.
61.	The project proponent shall strictly comply with the Building and other Construction Workers' (Regulation of Employment & Conditions of Service) Act 1996 and Gujarat rules made there under and their subsequent amendments.	IPRCL has submitted that building and other construction workers act are being complied.
62.	The overall noise level in and around the project area shall be kept well within the prescribed standards by providing noise	IPRCL has submitted that all the necessary arrangements have been adopted for regulating the noise generation even though the project

Jt. GENERAL MANAGER. (P)
IPRCL/GANDHIDHAM

	control measures including acoustic insulation, hoods, silencers, enclosures vibration dampers etc. on all sources of noise generation.	site is far away from the residential area.
63.	Ambient noise levels shall conform to residential standards both during day and night. Incremental pollution load on the ambient air and noise quality shall be closely monitored during construction phase.	IPRCL has submitted that the project site is far away from the residential area.
64.	The noise generating equipments, machinery and vehicles shall not be operated during the night hours and shall be maintained properly to avoid generation of high noise due to wear and tear.	IPRCL has submitted that the project site is far away from the residential area.
65.	Use of diesel generator sets during construction phase shall be strictly with acoustic enclosure and shall conform to the EPA Rules for air and noise emission standards.	IPRCL has submitted that D.G set with acoustic enclosure has been provided conforming to the EPA rules.
66.	Safe disposal of wastewater and municipal solid wastes generated during the construction phase shall be ensured.	IPRCL has submitted that Solid wastes and waste water are being disposed properly by making soak pits.
67.	All topsoil excavated during construction activity shall be used in horticultural / landscape development within the project site.	IPRCL has submitted that the excavated material is saline in nature, and it cannot be used for horticulture/ Landscape.
68.	The municipal solid wastes shall be properly collected and segregated at source.	IPRCL has submitted that Solid wastes are segregated and disposed properly.
69.	Recyclable solid waste [paper, cartons, plastic, polythene bags, glass etc.] shall be sold to the scrap vendors.	IPRCL has submitted that collected Solid waste is being sold to the scrap vendors.
70.	Non-recyclable municipal solid waste shall be transferred to the nearest designated waste collection point of the concerned local authority.	IPRCL has submitted that Solid waste shall be transferred to waste collection point of the concerned local authority.
71.	Provisions of Solid Waste Management Rules-2016 shall be strictly adhered to.	IPRCL has submitted that solid waste management Rules- 2016 are being strictly adhered to.
72.	The project must strictly comply with the rules and regulations with regards to handling and disposal of hazardous waste in accordance with the Hazardous Waste (Management, Handling and Transboundary) Rules 2008.	Point noted by IPRCL for compliance.

Jt. GENERAL MANAGER. (P)
IPRCL/GANDHIDHAM

	Authorization from the GPCB must be obtained for collection / treatment / storage / disposal of hazardous wastes.	
73.	Construction materials and debris shall be properly stored and handled to avoid negative impacts such as air pollution and public nuisances by blocking the roads and public passages.	IPRCL has submitted that construction material and debris are being stored properly to avoid blocking the roads.
74.	Construction debris shall be reused in construction of roads, levelling the site etc. Waste packaging material (like used cement bags, waste paper, cardboard packing material), metal scraps etc. shall be sold to recyclers or shall be sent to the nearest municipal solid waste landfill site.	IPRCL has submitted that waste material shall be sold to recyclers as and when required.
75.	The area temporarily used for storing the construction material and other activities shall be reclaimed by adequate Plantation.	IPRCL has submitted that Reclaimed will be being used for storing of construction materials and plantation will be done.
76.	Excavated earth to be generated during the construction phase shall be utilized within the premises to the maximum extent possible and balance quantity of excavated earth shall be disposed of with the approval of the competent authority after taking the necessary precautions for general safety and health aspects. Disposal of the excavated earth during construction phase shall not create adverse effect on neighbouring communities.	IPRCL has submitted that Excavated earth generated during the construction phase shall be utilized within the project area to avoid adverse effect on neighbouring communities.
77.	Provisions of Construction & Demolition Waste Management Rules-2016 shall be strictly adhered to.	Point noted by IPRCL for compliance.
78.	Vehicles hired for bringing construction material at the site shall be in good conditions and conform to applicable air and noise emission standards and shall be operated only during day time and non-peak hours.	Point noted by IPRCL for compliance.
79.	Project proponent shall ensure use of eco-friendly building materials including fly ash bricks, fly ash paver blocks, Ready Mix Concrete [RMC] and lead-free paints in the	IPRCL has submitted that Fly ash shall be used for ready mix concrete work.

 Jt. GENERAL MANAGER. (P)
 IPRCL/GANDHIDHAM.

	project.	
80.	Fly ash shall be used in construction wherever applicable as per provisions of Fly Ash Notification under the E.P. Act, 1986 and its subsequent amendments from time to time.	IPRCL has submitted that Fly ash is being used for ground improvement work and RE wall construction work.
81.	Use of glass shall be minimal and only low emissive glass shall be used in the project to reduce the electricity consumption and load on air conditioning.	IPRCL has submitted that usage is as per requirement.

B2. OPERATION PHASE AND LIFE TIME:

82.	Low water consuming devices shall be provided. Fixtures for showers, toilet, flushing and drinking shall be of low flow either by use of aerators/ diffusers or pressure reducing devices etc.	Low water consuming devices shall be provided at places whenever required.
83.	A water meter shall be installed on rain water harvesting & ground water recharge well system & compliance report of the same shall be submitted to concerned authorities.	Not applicable. As the project site area is saline in nature rain water harvesting is not possible.
84.	Used oil shall be sold only to the registered recycler.	Point noted for compliance. Used oil shall be sold to the registered recycler.
85.	Provisions of Solid Waste Management Rules-2016 shall be strictly adhered to.	Solid waste management Rules-2016 shall be strictly adhered to.
86.	Requisite firefighting facilities as per the requirement of NBC and Gujarat Fire Prevention and Life Safety Measures Act- 2013 along with the rules & regulations made there under shall be provided.	Point noted for compliance.
87.	First Aid Box shall be made readily available in adequate quantity at all the times.	Point noted for compliance.
88.	Necessary emergency lighting system along with emergency power back up system shall be provided. Further, necessary auto glow signage at all appropriate	Point noted for compliance.

 Jt. GENERAL MANAGER. (P)
 IPRCL/GANDHIDHAM

	places shall be provided to guide the people towards exits and assembly points during emergency.	
89.	The overall noise level in and around the project area shall be kept well within the prescribed standards by providing noise control measures including acoustic insulation, hoods, silencers, enclosures vibrations dampers etc. on all sources of noise generation including D.G. Sets. The ambient noise levels shall conform to the standards prescribed under the Environment (Protection) Act and Rules.	Standby power supply arrangements shall be provided conforming to the standards prescribed under the Environment (Protection) Act and Rules.
90.	Traffic congestion near the entry and exit points from the roads adjoining the proposed project site shall be avoided. No public space including the service road shall be used-or blocked for the parking.	IPRCL has obtained Proper diversion plan so that no blocking occurs.
91.	The project proponent shall install energy efficient devices, appliances, motors, and pumps conforming to the Bureau of Energy Efficiency norms.	The same has been provided wherever required.
92.	The transformers and motors. shall have minimum efficiency of 85%.	Point noted for compliance.
93.	Only variable frequency motor drives shall be used in project.	Point noted for compliance.
94.	Application of solar energy shall be incorporated for illumination of common areas, lighting for gardens and street lighting: In addition, the provision for solar water heating system shall also be provided.	Point noted for compliance.
95.	The area earmarked as green area shall be used only for plantation and shall not be altered for any other Purpose.	Point noted for compliance.
96.	Drip irrigation/flow volume, low angle sprinkler system shall be used for the lawns and other green area including tree plantation.	Point noted for compliance.
97.	The project proponent shall inform to SEAC. / SEIAA regarding the transfer of	N/A

 Jt. GENERAL MANAGER. (P)
 IPRCL/GANDHIDHAM

	management responsibility to the Society/Association to be formed for the proposed Project with all the supporting documents. The Society Association formed for further management of the proposed project shall be responsible for compliance of all the conditions stipulated in the Environmental Clearance order.	
98.	Environmental Clearance granted for the project on the basis of documents related to land possession submitted shall become invalid in case the actual land for the project site turns out to be different from the land considered at the time of appraisal of the project and mentioned in the EC.	The project will be executed within the land already under possession of DPT, as submitted in the application for Environment Clearance.
99.	All other statutory clearances such as NLA, permission, approvals for storage of diesel from PESO, Fire Department, Airports Authority of India etc., if applicable, shall be obtained by the project proponent from the competent authorities.	N/A
100.	All the conditions as may be stipulated in the NLA. order, Development permission, Building Use permission, NOC obtained from Fire Department etc. shall be strictly complied with.	N/A
101.	The project management shall also comply with all the environment protection measures, risk mitigation measures and safeguards proposed by them.	The environment protection measures, risk mitigation measures and safeguards proposed shall be complied.
102.	All the commitments/undertakings given to the SEAC during the appraisal process for the purpose of environmental protection and management shall be strictly adhered to.	Point noted for compliance.
103.	The project proponent shall also comply with any additional condition that may be imposed by the SEAC or the SEIAA or any other competent authority for the purpose for the environmental protection and management.	Point noted for compliance.

 Jt. GENERAL MANAGER. (P)
 IPRCL/GANDHIDHAM

104.	At the terms & conditions prescribed in the amendment of EIA Notification – 2006 published by the MoEF&CC vide its Notification No, S.O. 3999(E) dated 9th December, 2016 shall be complied with letter & spirit.	Conditions prescribed in the EIA notification 2006 shall be complied with properly.
105.	The project proponent shall strictly comply with the Gujarat Building and other Construction Workers' (Regulation of Employment & Conditions of Service) Rules 2003 as well as Gujarat Lifts & Escalators Rules as amended from time to time.	Point noted for compliance.
106.	No further expansion or modifications in the project likely to cause environmental impacts shall be carried out without obtaining prior Environment Clearance from the concerned authority.	Point noted for compliance.
107.	The above conditions shall be enforced, inter-alia under the provisions of the water (Prevention & Control of Pollution) Act, 1974, Air (Prevention & Control of Pollution) Act, 1981, the Environment (Protection) Act 1986 and the Hazardous Wastes (Management Handling and Tran boundary) Rules, 2008, Building and Other Construction Workers' (Regulation of Employment & Conditions of Service) Act-1996, The Gujarat Lifts and Escalators Act-2000 along with their amendments and rules.	As clarified in above points.

B. OTHER CONDITIONS

108.	The project proponent shall allocate the separate fund for Corporate Environment Responsibility (CER) in accordance to the MoEF&CC's Office Memorandum No. F.No.22-65/2017-IA.IN dated 01/05/2018 to carry out the activities under CER in affected area around the project. The entire activities proposed under CER shall be monitored and the monitoring	An amount of Rs. 1.75 Cr., has been earmarked as the CER budget for the project. The same shall be spent in different phases and the same shall be notified.
------	---	--

Jr. GENERAL MANAGER. (P)
IPRCL/GANDHIDHAM

	report shall be submitted to the regional office of MoEF&CC as a part of half-yearly compliance report and to district collector. The monitoring report shall be posted on the website of the project proponent.	
109.	The project authorities shall earmark adequate funds to implement the conditions stipulated by Forest & Environment Department., GOG / SEIAA as well as GPCB along with the implementation schedule for all the conditions stipulated herein. The funds so provided shall not be diverted for any other purpose.	Point noted for compliance.
110.	The applicant shall inform the public that the project has been accorded environmental clearance by the SEIAA and that the copies of the clearance letter are available with the GPCB and may also be seen at the Website of SEIAA/SEAC/GPCB. This shall be advertised within seven days from the date of the clearance letter, in at least two local newspapers that are widely circulated in the region, one of which shall be in the Gujarati language and the other in English. A copy each of the same shall be forwarded to the concerned Regional Office of the Ministry.	IPRCL got the advertisement published in EXIM INDIA (in English) and Kutchuday (in Gujarati) newspapers on dated 26/06/2020 and newspaper cuttings already sent to Regional office, Bhopal, MoEF&CC vide letter No.: EG/WK/4847(D)/III/922 dated 30/06/2020. The newspaper cuttings are attached as Annexure - VIII .
111.	It shall be mandatory for the project management to submit half-yearly compliance report in respect of the stipulated prior environmental clearance terms and conditions in soft copies to the regulatory authority concerned and shall be uploaded on website of Gujarat Real Estate Regulatory Authority, on 1 st June and 1 st December of each calendar year.	IPRCL shall submit the Compliance report periodically.
112.	The project authorities shall also adhere to the stipulations made by the Gujarat Pollution Control Board.	IPRCL has submitted that the GPCB stipulations shall be adhered to.

 Jt. GENERAL MANAGER
 IPRCL/GANDHIDHAM

113.	The project authorities shall inform the GPCB, Regional Office of MoEF&CC and SEIAA about the date of financial closure and final approval of the project by the concerned authorities and the date of start of the project.	(a) Date of start of project 01/10/2020. (b) Schedule date of completion 31/03/2023.
114.	The SEIAA may revoke or suspend the clearance, if implementation of any of the above conditions is not found satisfactory. This environmental clearance is valid for seven years from the date of issue.	IPRCL has submitted that conditions provided in the clearance issued by SEIAA will be implemented properly.
115.	Any appeal against this environmental clearance shall lie with the National Green Tribunal, if preferred, within 2 period of 30 days as prescribed under Section 16 of the National Green Tribunal Act, 2010.	Point noted for compliance.
116.	Submission of any false or misleading information or data which is material to screening or scoping or appraisal or decision on the application makes this environment clearance cancelled.	--



 Jt. GENERAL MANAGER (P)
 IPRCL/GANDHIDIP

QC COPY

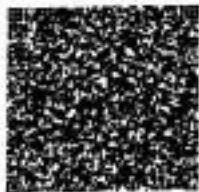

INDIA NON JUDICIAL
Government of Gujarat
Certificate of Stamp Duty

Certificate No.	IN-GJ95223355926842S
Certificate Issued Date	09-Jun-2020 12:34 PM
Account Reference	IMPACC (FI)/ gjelimp10/ MIRZAPUR COURT/ GJ:AH
Unique Doc. Reference	SUBIN-GJGJELIMP1029773190841899S
Purchased by	A K TIWARI AGM IPRCL ADI
Description of Document	Article 5(h) Agreement (not otherwise provided for)
Description	FOR MEMORANDUM OF UNDERSTANDING (*MOU)
Consideration Price (Rs.)	0 (Zero)
First Party	INDIAN PORT RAIL AND ROPEWAY CORPORATION LTD
Second Party	DEENDAYAL PORT TRUST
Stamp Duty Paid By	INDIAN PORT RAIL AND ROPEWAY CORPORATION LTD
Stamp Duty Amount(Rs.)	300 (Three Hundred only)



LB 0001815482

Statutory Alert

The authenticity of this document can be verified by visiting the website of the Government of Gujarat at www.gujarat.gov.in. The Government of Gujarat is not responsible for any loss or damage caused by the user of the website in case of any discrepancy between the original and the scanned copy.

WHEREAS

1. The Client is interested to take up the execution of the work of Construction of Interchange cum Road over Bridge (ROB) at LC 236 (Kutch Salt Junction) on NH 141 in the State of Gujarat.
2. The Client accordingly desires to avail the services of IPRCL for the purpose of execution of the Construction of Interchange cum Road over Bridge (ROB) at LC 236 (Kutch Salt Junction) on NH 141 in the State of Gujarat on EPC mode.
3. IPRCL is willing to render their services to the Client for Construction of Interchange cum Road Over Bridge (ROB) at LC 236 (Kutch Salt Junction) on NH 141 in the State of Gujarat.
4. Now therefore, in consideration of the mutual promises and covenants herein after contained, it is mutually agreed and declared by and between the parties here to as follows: -
5. The Work has been awarded in reference vide DPT's Letter dated 29.9.18, 29.10.19 & IPRCL Letter dated 25.06.18 & directions of Ministry dated 22.6.18.

ARTICLE 1 – DEFINITIONS AND INTERPRETATIONS

In this MOU, the following words and expressions shall, unless repugnant to the context or meaning thereof, have the meaning hereinafter respectively assigned to them;

- 1.1 'AFFECTED PARTY' shall have the meaning set out in Article 11.
- 1.2 'MOU' means this MOU and includes annexure hereto or any amendments thereto made in accordance with the provisions contained in this MOU.
- 1.3 'APPLICABLE LAW' means all laws, promulgated or brought into force and effect by the Government of India or any other concerned State Government including regulations and rules made there under, and judgments and orders of the Supreme Court of India, as may be in force and effect during the subsistence of this MOU.
- 1.4 'APPLICABLE PERMITS' means all clearances, permits, license authorizations, consents and approvals required to be obtained or maintained under Applicable Laws in connection with the design, engineering, financing, procurement, construction and commissioning of the project during the subsistence of this MOU.
- 1.5 'APPOINTED DATE' means the date of signing this MOU.
- 1.6 'APPROVAL and APPROVED' shall mean and include the written consent, either manuscript, type written or printed statement, under signature and seal, as the case may be, given from time to time by the Client or their authorized representative on documents, drawings or other particulars in relation to this MOU.

1A1

- 1.7 'COMMENCEMENT DATE OF CONTRACT' with reference to Works Contract for actual execution of works shall mean the date of Issue of official 'Work Order' from IPRCL to EPC Contractor that may be the date which is later of the 15th day of the date of work contract, the date on which the contractor has delivered the performance security in accordance with the provisions of Work Contract and the date on which IPRCL has provided the Right of Way on no less than 90% (Ninety Percent) of the total length of Project Highway.
- 1.8 'COMPLETION COST OF PROJECT' shall mean the final cost of construction to be incurred for completing the entire scope of work for commissioning of projects for its regular operation as assessed after finalization of all payments to contractors and other miscellaneous charges having been incurred for completion of work and such cost will be payable by the Client to IPRCL for executing the work of the projects under this MOU. This will include all duties, taxes, cess and other statutory levies payable by IPRCL for execution of the project.
- 1.9 'CONSTRUCTION' shall mean and include all activities necessary for a particular project and carry out all other acts that are incidental and related thereto commissioning of the project.
- 1.10 'CONSULTANT' shall mean any agency appointed by the Client for Preparation of Detailed Project Report (DPR), Carrying out Project Management Consultancy (PMC) and construction of Project.
- 1.11 'CONTRACT' shall mean this MOU including all exhibits hereto and all documents herein specified and amendments which the parties may hereafter agree in writing to be made to this MOU.
- 1.12 'CONTRACTOR' means any agency appointed by the Client for carrying out construction of different types of works involved in the project.
- 1.13 'COORDINATING OFFICER' shall mean the official nominated by the client to whom all the matters related to the Project shall be referred to by IPRCL for views, decisions, help, approvals etc. as per Scope of services of the Contract and who shall provide and communicate such views, decision, help, approvals etc. to IPRCL on behalf of the Client.
- 1.14 'DETAILED ESTIMATE' shall mean the detailed cost estimate of Project.
- 1.15 'DOCUMENT' OR 'DOCUMENTATION' means documentation printed or in written form, tapes, discs, drawings, computer programmes, writings, reports, photographs, cassettes, or expressed in any other written, audio or in any electronic/media/visual form.
- 1.16 'DRAWING' shall mean and include engineering drawings, sketches showing plans, sections and elevations related to the project together with modification and/or revisions thereto.
- 1.17 'ENGINEER/ENGINEER IN CHARGE' shall mean the person nominated by the IPRCL and shall include those who are expressly authorized by IPRCL to act for

AGM (F&P) IPRCL
Karnataka

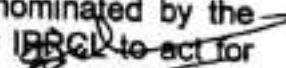
मुख्य अभियंता
चीनवयाल पोर्ट ट्रस्ट
Chief Engineer
Deendayal Port Trust

20



and on behalf of IPRCL for the provision of the services related to this MOU.

- 1.18 'MEASUREMENTS' shall mean all measurements and calculations in the metric system and calculations done to two decimal places, with the third digit of 5 or above being rounded up and below 5 being rounded down.
- 1.19 'MONTH' shall mean calendar month.
- 1.20 'PROJECT AREA' shall mean the area in which the construction work is going on/ proposed to be undertaken for the concerned Port.
- 1.21 'PROJECT COMPLETION' with reference to Works Contract shall mean the readiness of the works in all respects for use, after attending to minor repairs/adjustments.
- 1.22 'PROJECT IMPLEMENTING AGENCY' shall mean position as a CONSULTANT with regards to Preparation of FSR(Final Survey Report), Preparation of DPR and PMC as regards to Construction of the project.
- 1.23 'PROJECT or WORKS' shall mean the construction of civil, electrical and mechanical works for as per LOA (Letter of Acceptance).
- 1.24 'QUARTER or QUARTERLY' shall mean a period of three months commencing from April of each financial year.
- 1.25 'SERVICES' shall mean the responsibilities to be discharged by IPRCL for fulfilling the obligation under this MOU.
- 1.26 'STANDARDS' shall mean the goods and equipment utilized for the Works in the project and shall conform to the standards mentioned in the Technical specifications or such other standards which ensure an equal or higher quality and when no applicable standard is mentioned, to the authoritative standard appropriate to the goods/equipment utilized in the works in India and such standard shall be the latest issued by the concerned Institution like Bureau of Indian standards etc.
- 1.27 'SUB-CONTRACTOR or SUB-CONSULTANT' means any agency appointed by IPRCL for carrying out Preparation of FSR and DPR,PMC and Construction of different types of works involved in the project.
- 1.28 'VENDOR' means any agency appointed by IPRCL/Sub Contractor for supply of Goods/Equipment for the Project.
- 1.29 'WORKS CONTRACT' means the contract awarded by IPRCL to the sub-contractor for execution of the project.
- 1.30 "ENCUMBRANCES" shall mean any encumbrances such as mortgage, charge, pledge, lien, hypothecation, security interest, assignment, attachment privilege or priority of any kind having the effect of security or other such obligations and shall

AGM (P)/IPRCL
Ahmedabad.

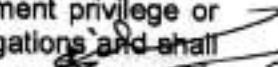
 Chief Engineer
 Daman Diu Port Trust

2
 101
 18

include without limitation any designation of loss to payees or beneficiaries or any similar arrangement under any insurance policy pertaining to the Project, physical encumbrances and encroachments on the Project Area where applicable herein.

- 1.31 "FORCE MAJEURE" OR "FORCE MAJEURE EVENT" shall mean an act, event, condition or occurrence as specified in Article 11.
- 1.32 "GOOD INDUSTRY PRACTICE" means those practices, methods, techniques, standards, skills, diligence and prudence which are generally and reasonably expected of and accepted from a reasonably skilled and experienced operator engaged in the same or similar type of undertaking as envisaged under this MOU and acting generally in accordance with the provisions of 'The Railways Act, 1989' and would inter-alia means good engineering practices in the design, engineering, construction and project management and which would be expected to result in the performance of its obligations by IPRCL and the Client and in the operation and maintenance of the Project in accordance with this MOU, Applicable Laws, Applicable Permits, reliability, safety, environment protection, economy and efficiency.
- 1.33 "GOVERNMENTAL AUTHORITY" includes Government of India hereinafter referred to as GOI, State Governments hereinafter referred to as GOS, any other department under the control of GOI or GOS having jurisdiction over all or any part of the Project or the performance of all or any of the services or obligations of IPRCL under or pursuant to this MOU, and having the authority and jurisdiction to frame laws, by-laws and rules, regulations, etc relating to the Project.
- 1.34 "AUTHORITY FOR ISSUE OF WORK ORDER", Chief Engineer vide letter No. HW/WK/1008-V/624 dated 29.09.2018., communicating the project of DEENDAYAL PORT TRUST to be executed by IPRCL.
- 1.35 'COMPLETION PERIOD' with reference to Works Contract shall mean the period from the commencement date of contract to project completion date.
- 1.36 'PHYSICAL COMPLETION', with reference to works contract shall mean readiness of the works contract except in minor respects, which does not prevent occupation of the works for the purpose for which the works have been designed.
- 1.37 'SPECIFICATIONS' shall mean and include schedules, detailed descriptions, statement of technical data, performance characteristics and standards as applicable and specified in the Works Contract.
- 1.38 'TEST or TESTING' shall mean such process or processes to be carried out by the IPRCL as are prescribed in the works contract in order to ascertain quality, workmanship performance and efficiency of goods/ equipment or part thereof.
- 1.39 'WRITING' includes matter either in whole or in part, in manuscript, typewritten,

lithographed, cyclostyled, photographed or printed form under or over signature or seal as the case may be.

1.40 In this MOU, unless the context otherwise requires:

(a) Any reference to a statutory provision shall include such provision as is from time to time modified or re-enacted or consolidated so far as such modification or re-enactment or consolidation applies to or is capable of being applied to any transactions entered into hereunder;

(b) Reference to Indian Law shall include the relevant laws, acts, ordinances, rules, regulations, or bye laws framed under any statute which has the force of law in any State.

(c) The words importing singular shall include plural and vice versa, and words importing the-masculine shall include the feminine gender.

(d) The words denoting natural persons shall include partnerships, firms, companies, corporations, joint ventures, trusts, associations, organizations, or other entities, duly incorporated.

(e) The headings are for convenience of reference only and shall not be used in and shall not affect the construction or interpretation of this MOU.

(f) Terms and words beginning with capital letters and defined in this MOU shall have the meaning ascribed thereto herein, and the terms and words defined in the Appendices and used therein shall have the meaning ascribed thereto in the Appendices;

(g) The words "include" and "including" are to be construed without limitation; only to the subject concerned.

(h) Any reference to any point in time shall mean a reference to that point according to Indian Standard Time;

(i) Any reference to day shall mean a reference to a calendar day;

(j) Any reference to month shall mean a reference to a calendar month;

(k) The Appendices to this MOU form an integral part of this MOU and will be in full force and effect as though they were expressly set out in the body of this MOU;

(l) Any reference at any time to any MOU, deed, Instrument, license or document of any description shall be construed as reference to that MOU, deed, instrument, license or other document as amended, varied supplemented, modified or suspended at the time of such references;

(m) References to Recitals, Articles, sub-Articles, Paragraphs, or Appendices in this MOU shall except where the context otherwise requires, be deemed to be references to Recitals, Articles, sub-Articles, Paragraphs, and Appendices of or to

this MOU.

(n) Any reference to any period commencing "from" a specified day or day and 'till' or 'until' a specified day or date shall include both such days and dates;

(o) The several documents forming this MOU are to be taken as mutually explanatory to one another and unless otherwise expressly provided elsewhere in this MOU, the priority of the following documents shall in the event of any conflict between them be in the order they are set out below

- i) This MOU.
- ii) All other documents forming part of this MOU.

i.e. documents at (i) above shall prevail over the documents at (ii) above.

ARTICLE 2 – SCOPE OF WORK AND OBLIGATION OF IPRCL:

The scope of the services to be rendered by the IPRCL for Construction of Interchange cum Road Over Bridge (ROB) at LC 236 (Kutch Salt Junction) on NH 141 in the State of Gujarat shall be as per requirement of DEENDAYAL PORT TRUST specified as under,

- 2.1. Detail survey of area and site investigation.
- 2.2. Detail Plan based on approved GAD Drawings and Diversions Plan with Railways and MoRTH standards
- 2.3. Preparation of Revised Estimated cost for the project & submission to DPT.
- 2.4. Invitation of tender to finalization of tender i.e. award of work to the successful bidder
- 2.5. To supervise the entire execution of work during construction and Operation & Maintenance phase.
- 2.6. Shifting / removing of all hindrances / utilities shall be included in the scope of the EPC Contractor to be appointed by the IPRCL and same shall be supervised by the IPRCL.
- 2.7. All statutory clearances including Environmental / CRZ / Pollution Control clearances required, if any, shall be obtained by the IPRCL.
- 2.8. To work out the data, drawings and plan of existing and proposed structures open/underground/concealed utilities etc. However, available data, plans, drawings, tender documents etc available with DPI shall be provided to IPRCL.
- 2.9. Ensuring that the construction is being carried out in accordance with the approved working designs, drawings and specifications and as per programme laid down in the Works Contract.

AGM (P) IPRCL
Ahmedabad.

मुख्य अभियंता
दीनदयाल पोर्ट ट्रस्ट
Chief Engineer
Deendayal Port Trust

- 2.10. Ensure quality control of the works contract including materials and workmanship, certify measurement of work executed, and releasing progressive payments based on physical realization/completion of works, as per approved procedure and schedule of payments to Sub-Contractors.
- 2.11. IPRCL shall take complete responsibility for Sanction of Extension of time for Works, with or without Liquidated damages, with full details including the effect on completion cost of works, if any as per Work contract. In case extension is granted with imposition of liquidated damages, the benefit of the same will be passed over to the client as the same is deducted from the contractor's bill.
- 2.12. Making available to client the documents pertaining to finalization or accounts and closing Works Contracts.
- 2.13. Ensure for settling the claims/disputes, if any on behalf of client. All amounts payable to the Sub-Contractor/Sub-Consultant on his claims decided by arbitration/courts client directly and agreed to by the sub-contractor/Sub-Consultant will be charged to the cost of works. For settlement of disputes, if any, with the Sub-Contractor/Sub-Consultant, IPRCL shall nominate the arbitrator.
- 2.14. If no Agreement is reached by discussions, the issue will be settled through Arbitration under Article 13 of this MOU. Pending decision by the Arbitrator, the amount covered by such items of award will be tentatively charged to cost of works.
- 2.15. Attend to the inspection, if any, carried out by Government Agencies such as central vigilance commission, railways and comply with their statutory requirement and effectively arrange for replying to their observations.
- 2.16. Getting defects if any rectified by the deployed Sub-Contractor during the 'Defect Liability Period'.

ARTICLE 3 – OBLIGATIONS OF THE CLIENT:

- i). To make available the land required for the proposed ROB including land for Diversion of road if required to construct ROB at same location..
- ii). To extend the help/co-ordination to M/s IPRCL for correspondence with State Government, local authorities as and when required.
- iii). To make available the funds to M/s IPRCL as per the agreed cash flow statement during the construction of the project
- iv). To make payment to State Government/Local authorities, on the recommendation of the M/s IPRCL, as required for any approvals or for utility shifting or payment for any other statutory works from such authorities.

AGM (P) IPRCL
Ahmedabad.

मुख्य अभियंता
चीनदयाल पोर्ट ट्रस्ट
Chief Engineer
Deendayal Port Trust

- v). Necessary Agreement with railway is to be executed by the DPT for ROB project on the advice/Technical vetting of M/s IPRCL and after completion of work ROB project is to be taken in possession by DPT.
 - vi). All statutory fees, codal charges payable to railway etc. shall be paid by the DPT directly on advice of IPRCL.
- 3.1. The client will arrange to furnish existing layout plan for utilities and services, if any, in the area where new works are proposed.
 - 3.2. The Client will nominate a suitable officer as the coordinating officer who shall perform the duties as listed in Article 1.13.
 - 3.3. The Client shall permit or arrange to permit the entry of IPRCL's person for survey and collection of other data as required for executing the scope of work.
 Client shall make reasonable efforts to assist IPRCL in obtaining clearances at both the Central and State Government levels for the performance of its rights and obligations under this MOU, if any, for the works and shifting/relocating existing utilities as necessary.
 - 3.5. The Client will communicate their decisions whenever referred to, preferably within 15 days of such a request from IPRCL.
 - 3.6. Any material property or other asset presently at the site to be replaced by new assets, property or material as the case may be are to be disposed of by the Client at their sole discretion; and if any credit is realized on account of such disposal, the same shall be credited to the Client and shall not be the part of Completion Cost of the Project.
 - 3.7. Client shall provide IPRCL's personnel assigned to site the following facilities comparable to clients own personnel for similar categories subject to availability on payment basis:
 - a) The Client shall provide office and quarters / accommodation with electric and water supply connection to IPRCL's personnel posted at site on payment of charges laid down by the Client subject to its availability.
 - b) The Client shall provide guest house accommodation to IPRCL's personnel visiting site on payment of charges laid down by the Client, subject to its availability.

9 | Page

AGM (P) IPRCL
Ahmedabad.

मुख्य अभियंता
दीनदयाल पोर्ट ट्रस्ट
Chief Engineer
Deendayal Fort Trust

ARTICLE 4 – IPRCL'S Charges:

4. IPRCL shall execute the work of ROB project on behalf of DPT on direct cost plus charges basis. The charges shall be as under:

4.1 The centage/charges for EPC mode of work execution:

a.	Contingency	2.8%
b.	IPRCL charges	3.0%
c.	Quality control	0.5%
d.	Road safety	0.5%
e.	Supervision (Independent Engineer)	4.0%

4.2 The supervision charges for independent engineer/Authority's Engineer of 4% as indicated shall be paid to IPRCL. IPRCL shall appoint independent engineer/Authority's Engineer consulting firm through open bidding process in transparent manner.

4.3 Direct cost of Project shall also include:

- i) Charges for survey, design, payment for consultants for preparation of working drawings and completion drawings.
- ii) Cost of complete ROB work to be executed including all Labour material, machinery required for completion of work include.
- iii). Any other expenditure incurred at the instruction of the DPT.
- iv). GST, other Statutory Dues or any cost overruns due to increase in taxes and duties as applicable during the Completion Period/Date of billing will be payable extra.
- v). Stages of payment of remuneration to charges will be as per Annexure 'A'.
- vi). After the execution of this MOU, Client shall pay to IPRCL, all the outstanding fees as per the bills issued by IPRCL till date.

4.4 IPRCL's Fund Projection for Construction Activity:

- a) DPT shall pay 10% of the Total Project Cost to IPRCL as advance for taking up the project in priority.
- b) At the 1st day of the previous month of Every Quarter, IPRCL will make projection of funds as required for execution of each work as per which the Client shall make payment to IPRCL. The amount will be interest free.

**AGM (P)IPRCL
Ahmedabad.**

**मुख्य अभियंता
दीनदयाल पोर्ट ट्रस्ट
Chief Engineer
Deendayal Port Trust**

- (3)
- c) On the receipt of the Running Account bills of Sub-Contractors, the same shall be billed to the Client by IPRCL against the funds so received from the Client.
 - d) Client shall deduct TDS as per provision of the Income Tax Act, 1961, as amended from time to time, on the payments made towards the fund projection for Construction.
 - e) GST, other Statutory Dues or any cost overruns due to increase in taxes and duties as applicable during the Completion Period/Date of billing will be payable extra.
 - f) GST on the cost will be levied as applicable under the extant rules.
 - g) All payments made by the Client to IPRCL till date of MOU will be adjusted against the bills issued till date of MOU by IPRCL.

ARTICLE 5 – COMPLETION COST OF WORK TO BE BORNE BY CLIENT:

- a) Gross amount paid to the Vendors, Structural Designers, Site Engineers etc and Construction Costs incurred towards Construction of the Projects as per this MOU.
- b) Cost of any materials supplied free to the IPRCL including Cost of handling, transportation and storage incurred by the client.
- c) Charges, if any, levied by the Local Authorities/Departments/Railways for approval of plans and services and for issue of "Completion/ No-Objection" Certificate for occupation of the works on completion.
- d) Charges, if any, levied by the Local Authorities / Providers of Services such as water Supply, Drainage, Sewerage, etc. for the shifting/relocation of utilities as well as their disconnection /connection.
- e) Cost of litigation, if any, with a Third party or individual organization to remove legal barriers in the execution works.
- f) Cost of testing materials/workmanship for items for which the IPRCL is not required to pay in terms of the provisions in the work contracts.
- g) Any amount paid/payable to the IPRCL/Sub-Contractor towards his claims as considered reasonable.
- h) Any amount paid/payable to the IPRCL/Sub-Contractor towards his claim not accepted by the client but decided in the favor of IPRCL by an Arbitrator or Court of Law.
- i) Any justified and acceptable claims made by the sub-contractor.
- j) IPRCL shall undertake the execution of the project under this MOU as per the Detailed Estimate approved by the client. In case of any increase in the cost of execution of the works irrespective of % in cost beyond sanctioned estimate before executing the same, IPRCL shall take prior consent of the Client. Such excess cost to be incurred shall form part of the "Completion Cost of the Project" which shall be the total cost to be paid by the Client to IPRCL.
- k) The Cost of hire charges of vehicle engaged on site is already included in IPRCL Charges and will not be claimed extra.

ARTICLE 6-PROJECT PLANNING AND MONITORING AND PROGRESS REPORTING:

6.1.1. IPRCL shall submit an overall Projects Schedule in the form of a Network on time scale highlighting all major milestones of the Project. This shall be approved by

11 | Page

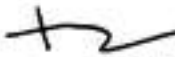
AGM (P) IPRCL
Ahmedabad.

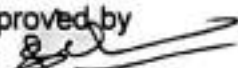
मुख्य अभियंता
बीजवदा पोर्ट ट्रस्ट
Chief Engineer
Bijavda Port Trust

59

the Client and would form the basis for monitoring as well as detailing function schedules. IPRCL shall update this document once in every quarter and submit to the Client.

- 6.1.2. Deficiencies, if any, pointed out by the Client, Concerned Chief Engineer of DPT or other such officers concerned during the inspection will be promptly attended to by IPRCL, to the extent each party is responsible for the deficiency to the entire satisfaction of the inspecting authorities.
- 6.1.3. During the construction, the Client shall be allowed to undertake periodic inspections through its own authorized representative to satisfy itself regarding the quality, progress and quantity before any payment to IPRCL. After the completion of all Construction Works, IPRCL shall be responsible for obtaining necessary Safety Certificate any other clearance issued by the concerned authorities for the Project as the case may be.
- 6.1.4. Monthly reports will be sent by IPRCL/Sub-Contractor to the client so as to reach him by Fifteenth of the next month as per format to be mutually agreed to.
- 6.1.5. Review meetings to be organized by the client will be held at mutually decided intervals either at site or at the client's office as decided by the Client and IPRCL.

ARTICLE 7-PAYMENT TO IPRCL AND ACCOUNTAL PROCEDURE:

- 7.1 The IPRCL shall make financial projections for the funds at 1st day of the previous month of every Quarter. The Client shall release the funds on requisition of advance by IPRCL.
- 7.2 Billing and Payment shall be as follows: ✓
- a).IPRCL shall issue separate bills for the construction activity.[Refer Article 4.4]. ✓
- b) Any other taxes, which are levied as per the statutory provisions, if any, at the time of billing or construction period would also be borne by the Client.
- 7.3 Whenever the need arises for obtaining Revised Sanction of Expenditure from the Client, IPRCL shall take prompt action to approach the Client with full justification.
- 7.4 After completion of work, IPRCL will prepare detailed statement of accounts as per agreed formats covering various works contract wise and the expenditure thereof duly certified with necessary supporting documents, including copies of final bills and 'As built' drawings, duly certified by the IPRCL's Engineers containing all the details of the work.
- 7.5 If the Client fails to deposit the requisite amount or delays communicating decisions to IPRCL, leading to cost overrun then the Client shall be liable for payment of any additional costs incurred by IPRCL due to such delays.
- 7.6 In case of failure to meet the obligation on either side i.e, DPT or IPRCL shall bear the additional expenditure due to cost overrun.

ARTICLE 8- DUE DILIGENCE, CLAIMS AND LIABILITIES:

The Client and IPRCL agree to abide by all principles of due diligence and good Industry Practices as well as provisions relating to exercise of diligence.

Any claims and liabilities arising out of the execution of the project shall be settled by IPRCL subject to the observances of all the normal rules and regulations of IPRCL in force at that time. Cost incurred on this account shall form part of the Completion Cost of the Project except cost due to negligence/failure on the part of IPRCL.

ARTICLE 9 – BREACH OF CONTRACT AND OTHER FAILURES TO PERFORM:

In the event of IPRCL or the Client being in material default unless arising as a result of Force Majeure of this MOU and such default is not cured before the expiry of the remedy period, the defaulting party shall pay to the other party as compensation, all direct additional costs suffered or incurred by the concerned party arising out of such material default, including cost of work carried out.

9.1 IPRCL's event of Default:

The following (unless arising as a result of Force Majeure Event or Client's default) shall constitute IPRCL's Events of Default:

- i. Non-performance of any acts set forth in this MOU for a continuous period of 60 days.
- ii. Repudiation of this MOU by IPRCL or the evidencing of an express intention by IPRCL not to be bound by the terms of this MOU.

9.2 Client's event of Default:

The following (unless arising as a result of Force Majeure Event or IPRCL's default) shall constitute Client's event of default:

- i. Repudiation of this MOU by the Client or the evidencing of an express intention by the Client not to be bound by the terms of this MOU.
- ii. Appointment of a provisional liquidator providing for winding up of the Client unless such appointment is set-aside.
- iii. Non- deposition of requisite amount to IPRCL as per Article 7 of this MOU.
- iv. Non-performance of any act set forth in this MOU for a continuous period of 60 days.

9.3 Consequences of Default:

In the event of IPRCL's Event of Default or Client's Event of Default ("Event of Default") the termination procedure as set out in the following clauses shall apply.

9.4 Notice of Intent to Terminate cum Remedy Period:

- i. On the happening of any Event of Default as set out herein above, the non-defaulting party may initiate termination of this MOU by delivering a notice to the Defaulting Party of intention to terminate this MOU (Notice of Intent to Terminate).

AGM (P) IPRCL
Ahmedabad.

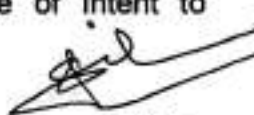
मुख्य अभियंता
हजिरापोर पोर्ट ट्रस्ट
Chief Engineer
Hazira Port Trust

- (57)
- ii. The Notice of Intent to terminate shall specify with reasonable details the defaults committed by the defaulting party, giving that Party 30 days ("Remedy Period") to cure the Event of Default.
 - iii. During the Remedy Period, the Defaulting Party shall continue to undertake efforts to cure the default, and the Non Defaulting party shall not, by any act or omission, impede or otherwise interfere with the Defaulting party's endeavors to remedy the Event of Default.
 - iv. During the Remedy Period, both the parties (Client and IPRCL) shall jointly make sincere efforts to resolve the differences, if any in the understanding by mutual discussions before resorting to termination procedure.
 - v. During the Remedy period, both the parties (Client and IPRCL), save as otherwise provided herein, should continue to perform their respective obligations under this MOU.

9.5 Withdrawal of Notice of Intent to Terminate:

If, during the Remedy Period, the Defaulting Party rectifies or remedies the default to the satisfaction of the Non-Defaulting Party or the Non-Defaulting Party is satisfied with steps taken or proposed to be taken by the Defaulting Party in such a manner that the Event of Default giving rise to the Notice of Intent to Terminate has ceased to exist, the Non-Defaulting party shall withdraw the Notice of Intent to Terminate.

9.6 Termination:

- i. In the case that an event of default has not been rectified within the remedy period and except where the parties have otherwise agreed or the Event of Default giving a cause to the Notice of Intent to Terminate shall have ceased to exist, the Non-Defaulting party, may terminate this MOU by issuing a Final Termination Notice to the Defaulting party.
- ii. Upon the issuing a final termination notice to the defaulting party, this MOU shall be terminated and the provisions of Articles 9.7 and 9.8 shall be applicable.

9.7 Compensation Payable by Client to IPRCL- Client's Event of Default:

In the event of Client's Event of Default, Client shall pay to IPRCL all reimbursements of advances and all financial and contracted liabilities and obligations made by IPRCL to sub- contractors/sub-consultants. Client shall also discharge on behalf of IPRCL all other liabilities both direct as well as consequential, which have been incurred by IPRCL towards fulfilling its obligations under the terms of this MOU.

9.8 Compensation Payable by IPRCL to the Client - IPRCL's Event of Default:

In the event of IPRCL's Event of Default, the Client shall have the option of getting the balance work executed and completed by another agency. In such an eventuality payment to IPRCL shall be made for the entire cost of work actually executed and the liabilities already incurred by IPRCL.

9.9 In the event of termination of this MOU, Client and IPRCL shall jointly inspect and

measure the works executed. IPRCL shall provide all documents or any data or records regarding the construction of the project to enable the Client to complete the construction works of the Project.

ARTICLE 10 – INDEMNITY

- i. The Client will indemnify, defend and hold IPRCL harmless against any and all proceedings, actions and third party claims (other than a claim by IPRCL or loss, damage and expenses of whatever kind and nature arising out of design, engineering, construction of the project and claims arising out of a breach by the Client of any of its obligations under this MOU except to the extent any such claim has arisen due to IPRCL's event of Default).
- ii. IPRCL will indemnify, defend and hold the Client harmless against any and all proceedings, actions and third party claims for loss, damages and expenses of whatever kind and nature arising out of for defect in title and/ or the rights of IPRCL in the land comprised in the project Area adversely affecting the performance of the Client's obligations under this MOU and /or arising out of acts done in discharge of their lawful functions by IPRCL, its officers, servants, agents, subsidiaries and contractors including IPRCL's events of Default except to the extent that any such claim has arisen due to negligent act or omission, breach of contract or breach of statutory duty on the part of the Client.

ARTICLE 11 – FORCE MAJEURE

11.1 Force Majeure shall mean any event or circumstance or combination of events or circumstances that materially and adversely affect the performance by either Party (the "Affected Party") of its obligations under this MOU (including by preventing or hindering or delaying such performance), but only if and to the extent that such events and circumstances in all possibility are not within the Affected Party's reasonable control. The following are the circumstances of Force Majeure to the extent that they or their consequences satisfy the above requirements:

- a) The effect of natural elements or other acts of God, including but not limited to any storm, flood, drought, lightning, earthquake, cyclone or other natural disaster,
- b) Fire, accident, breakage of facilities or equipment, structural collapse or explosion which the Party claiming to have been subject to Force Majeure demonstrates to have been attributable to a cause other than Inherent defects of any equipment, or circumstances within the reasonable control of the Affected Party or its contractors,
- c) epidemic or quarantine acts of war (whether declared or undeclared), sabotage, terrorism or acts of public enemy (including the acts of independent units or individuals engaged in activities of foreign program of irregular welfare), acts of belligerence of foreign enemies (whether declared or undeclared), blockades, embargoes, civil disturbances, revolution, rebellion or insurrection, exercise of military or usurped power or any attempt at usurpation of power;
- d) Radioactive contamination or ionization radiation.
- e) Events of strikes, work to rule actions, go-slows or similar labour related problems caused in whole or in part by agitation or unrest having a severe impact on the project.
- f) Any circumstance or event beyond the control of either party such as any legal

proceedings related to land or the construction and agitation or similar steps taken by any member of public against implementing any part of the project on ground of environment, public interest or similar grounds.

11.2 Duty to Report:

11.2.1 A Party claiming to be affected by an event of Force Majeure shall notify the other Party in writing of the occurrence of the event of Force Majeure as soon as reasonably practicable, and in any event, within 30 (thirty) days after the Affected Party knew, or ought reasonably to have known, of Force Majeure is likely to have on the performance of its obligations under this MOU. Any notice pursuant to this Article 11.2.1 shall include full particulars of:

The nature and extent of the event of Force Majeure which is the subject of any claim for relief under this Article 11.2.1 with evidence in support thereof;

- The estimated duration and effect or probable effect which such event of Force Majeure is having or will have on the Affected Party's performance of its obligations under this MOU; and
- The measures which the Affected Party is taking or proposes to take, to alleviate the impact of such event of Force Majeure; and
- Any other information the Affected Party wishes to present in support of its claim.

11.2.2 For so long as Affected Party continues to claim to be affected by such event of Force Majeure, it shall continue to provide to the other Party written reports every 7 days, containing information as required by this Article and such other information as the other Party may reasonably request the Affected Party to provide.

11.2.3 Any party claiming to have been affected by an event of Force Majeure shall not be entitled to any relief unless it has complied with all the provisions of this Article.

11.3 Excuse from performance of obligations

11.3.1 An Affected Party who is rendered wholly or partially unable to perform its obligations under this MOU shall be excused from performance of such of its obligations as are directly and materially adversely affected by the event of Force Majeure, provided however that;

- (a) An obligation to make any payment or meet any financial obligation shall not be excused on account of an event of Force Majeure;
- (b) The maximum period for which relief can be claimed by an Affected Party in respect of an event of Force Majeure shall not exceed sixty (60) days;
- (c) the suspension of performance of its obligations by the Affected Party shall be of no greater scope and of no longer duration than is reasonably necessitated by the event of Force Majeure;
- (d) the Affected Party shall continue to make all reasonable efforts to mitigate or limit the damage to the other Party arising out of or as a result of the event of Force Majeure.

or occurrence of such event of Force Majeure and to cure the same with due diligence' and

- (e) when the Affected Party is able to resume performance of its obligations under this MOU, it shall give to the other Party written notice to that effect and shall promptly resume performance of its obligations hereunder.

11.4 In the event the Force Majeure continues beyond 60 days, the affected party or parties shall mutually agree upon in writing for an alternative arrangement.

11.5 No Liability for other losses, damages, etc.

Save and except as expressly provided in this Article 11, neither Party shall be liable in any manner whatsoever to the other Party in respect of any loss, damage, cost, expense, claims, demands and proceedings relating to or arising out of the occurrence or existence of any event of Force Majeure or the exercise by it or any right pursuant to this Article 11.

11.6 Termination Notice

If a Force Majeure Event subsists for a continuous period of 60 (sixty) days, the MOU may be terminated by either party by giving a Termination Notice in writing.

ARTICLE 12-SETTLEMENT OF DISPUTES THROUGH GOOD FAITH NEGOTIATIONS AND CONCILIATION

12.1 Good Faith Negotiation

The Parties shall endeavor, in the first instance, to resolve any dispute, dis MOU or difference arising out of or in connection with this MOU, including any question regarding its performance, existence, validity, termination and the rights and liabilities of the Parties to this MOU (a "Dispute") through good faith negotiations.

12.2 For the purpose of conducting good faith negotiations, each Party shall, within one month of the Appointed Date, designate in writing to the other Party a representative who shall be authorized to negotiate on its behalf with a view to resolving any Dispute (the "Representative"). Each such Representative shall remain so authorized until his replacement has been designated in writing to the other Party by the Party he represents.

12.3 Unless otherwise provided for in this MOU, the following provisions shall apply to the resolution of any Dispute:

- i. The Dispute shall not be referred to Arbitration under Article 14, unless and until the provisions of this Article have been complied with.
- ii. The representative of the Party which considers that a Dispute has arisen shall give to the Representative of the other Party, a written notice setting out the material particulars of the Dispute (a "Dispute Notice").
- iii. Within thirty days, or such longer period as may be mutually agreed (the "Negotiation Date"), of the Dispute Notice having been delivered to the other

(3)

Party, the Representatives of both Parties shall meet in person at the registered office of the Company or at any other designated place to attempt in good faith, and using their best endeavours at all times, to resolve the Dispute. Once the Dispute is resolved, the terms of the settlement shall be reduced in writing and signed by the Representatives of the Parties (the "Settlement"); and If a settlement is not reached within thirty (30) days after the Negotiation Date, such Dispute shall be referred for Conciliation to one conciliator to be decided mutually.

ARTICLE 13 – ARBITRATION

- 13.1 If good faith negotiation and conciliation under Article 12 has not been able to resolve a Dispute, such Dispute shall be settled in terms of Office Memorandum No. 4 (1)/2011-DPE(PMA)-GL dated 12.06.2013 or issued by Ministry of Heavy Industries and Public Enterprises, Department of Public Enterprises and its amendment from time to time.
- 13.2 Any Party aggrieved by such award may make a further reference for setting aside or revision of the Award to the Secretary Shipping, Ministry of Shipping, Govt. of India. Upon such reference, the dispute shall be decided by the Secretary Shipping, Additional Secretary when so authorized by the Secretary Shipping, whose decision shall bind the parties finally and conclusively. The parties in the dispute will share equally the cost of arbitration as intimated by the Arbitrator.
- 13.3 The place of arbitrations shall be Ahmedabad.

ARTICLE 14 – WAIVERS

- 14.1 Waiver by either Party of any default by other party in the observance and performance of any provision of or obligation of or under the MOU:-
- i. Shall not operate or be construed as a waiver of any other or subsequent default hereof or of other provisions or obligations under this MOU.
 - ii. Shall not be effective unless it is in writing and executed by a duly authorised representative of the Party; and
 - iii. Shall not affect the validity or enforceability of this MOU in any manner.

Neither the failure by either Party to insist on any occasion upon the performance of the terms, conditions and provisions of this MOU or any obligation there under nor time or other indulgence granted by a Party to the other Party shall be treated or deemed as waiver of such breach or acceptance of any variation or the relinquishment of any such right hereunder.

ARTICLE 15 – LABOUR LAWS

- 15.1 IPRCL shall undertake to ensure compliance of all labour laws which are applicable to their workmen and also obtain through suitable provision in the Works Contracts commitments by the sub-contractors to whom any part of the Works Contracts envisaged under this MOU is entrusted, in respect of their workmen. The Client will be the Principal Employer

AGM (P) IPCL
Ahmedabad.

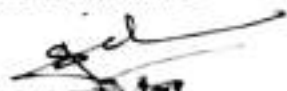
मुख्य अभियंता
कोलकाता पोर्ट ट्रस्ट
Chief Engineer
Kolkata Port Trust

15.2 IPRCL shall be responsible for all statutory obligations and any other laws in the above regard, in force from time to time, regarding employment or conditions of service of their Sub-Contractors and employees.

15.3 IPRCL shall ensure compliance by the Sub-Contractors of all safety rules as required under various statutes in India, through suitable provision in the works contracts.

15.4 IPRCL shall incorporate third party risk clause in all works contracts awarded by the Client, so as to ensure that the Client is held harmless and indemnified against any damage or injury to third party on account of any act or omission to act by the employees or representatives engaged for the execution of the work.

ARTICLE 16-MODIFICATION IN THE WORKS CONTRACTS.

Deleted

ARTICLE 17 - TIME SCHEDULE.

17.1 Time is the essence of Contract.

17.2 IPRCL shall furnish time schedule for activities mentioned in Article 2 to the Client.

17.3 IPRCL shall furnish to the Client a detailed time-schedule for execution of works including tendering process after finalization of the detailed estimate based on detailed designs and drawings.

17.4 IPRCL shall make all efforts to get the works executed as per the time schedule finalized by IPRCL with the Client.

17.5 IPRCL shall not be responsible for any delay in completion of the project and other consequential liabilities, due to failure of the Client to deposit with IPRCL, funds for execution of the project as per the stipulated schedules.

ARTICLE 18 - AMENDMENTS TO MOU:

Any amendments or modifications to this MOU must be in writing and shall be signed by both the parties.

ARTICLE 19-TIME LIMIT FOR VALIDITY OF THIS MOU:

19.1 This MOU will be valid for 90 days beyond the date when all the following documents are made available by IPRCL to the Client.

A) Final accounting after closing of works (refer Article 7)

Note: When there is no Arbitration/Court proceeding on any claim by works Contractor, The Final Accounts will be made out for each such work forming part of the project, in one part. When there is any Arbitration /Court Proceeding of any claim by the works Contractor, The Final Accounts for each work will be submitted by IPRCL in two parts with the first comprising of all items other than

(5)

those covered by Arbitration/Court Proceedings and second and final part comprising of items arising out of the Arbitration/Court Award.

B) Two copies of "As Built Drawings" on reproducible paper.

C) Insurance Policy on works, if any.

19.2 Any request for clarifications desired by the client on items in (a) above or any other item pertaining to the MOU or for copies of any missing documents should be made to IPRCL within a period of 30 days from the date of receipt by the Client of each of the documents in (a) above. If no such request is received within the period of 30 days as mentioned above, the Client shall be deemed to have waived his right to ask for such clarifications and copies of missing documents.

19.3 Where the request for clarifications and/or copies of missing documents has been received within the period of 30 days as mentioned above and IPRCL fails to furnish his response within the limit of 30 days before expiry of validity of the MOU as defined in para (a) above, the Validity of MOU shall be automatically extended for a further period of 30 days from the date when the request of the client is complied with in IPRCL.

ARTICLE 20 - TERMINATION OF MOU:

- a) The MOU herein may be terminated at any time, if any unavoidable circumstance occurs, the either party (Client/IPRCL) by giving a written notice of two months to other party. With the termination of MOU, the Works Contracts will be operated by the client. Even after the termination of the MOU, IPRCL shall be liable and responsible for the due certification at any time, in respect of the Work executed before the termination of the MOU.
- b) In case there is any change in the constitution of IPRCL, the details will be promptly communicated to the Client. In the case the Client is in the opinion that this will affect the performance of the IPRCL under this MOU, the Client shall be entitled to terminate this MOU after giving due notice and entrust the work to some other agency.
- c) In case of the termination under para "a" or "b" IPRCL shall not be entitled to fees or compensation except the fees payable to them for the work actually executed. The amount of fess so payable shall be decided in mutual discussion between the Client and IPRCL.
- d) In case of the Termination under para "a" the client may make use of all or any drawings, estimates or other documents prepared by IPRCL, after a reasonable payment for the services of IPRCL for preparation of the same.

ARTICLE 21 - CONFIDENTIALITY:

Each party agrees to treat as confidential, all document and other information and negotiation concerning technical, economic and marketing information of other party in connection with this MOU and shall not disclose or make public any such information

20 | Page

AGM (P) IPRCL
Ahmedabad.

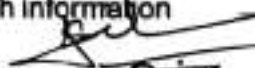
मुख्य अभियंता
चीनव्याल पोर्ट ट्रस्ट
Chief Engineer

D

30
unless prior consent and approval of other party is obtained in order to disclose the same. However this restriction shall not be applicable in respect of any publicly available information.

ARTICLE 22 – CHANGE IN LAW:

22.1 Definition:

A) Change in Law shall mean the occurrence of any of the following events after the Effective Date of this MOU:

- a) The enactment of any new applicable law;
- b) The modification, repeal or re-enactment (other than a re-enactment which merely consolidates or codifies existing applicable law) of any existing applicable law;
- c) The commencement of any applicable law which had not at the Effective Date yet entered into effect except to the extent such applicable law was enacted prior to the Effective Date with a commencement after the Effective Date and such applicable law takes effect on that commencement date without material amendment;
- d) Any change in the interpretation or application of any applicable law by judicial or other authority (including a court, tribunal or any other regulatory authority) having the authority to interpret or apply that applicable law or any interpretation of any applicable law by such authority which is contrary to the existing generally accepted interpretation thereof;
- e) The revocation or cancellation (other than for cause) of any permit, or
- f) Designation or re -designation of the Project, to the extent that such Change in Law has a material adverse effect on the rights and obligations of IPRCL under this MOU and that such event has not been caused due to the fault or negligence of IPRCL.

B) Notwithstanding anything contained in clause (a) hereinabove, Change in Law shall not include any change in the tax laws or change in law in general applicability but which solely has an economic and financial impact on IPRCL.

22.2 Notification of Change in Law:

- a) IPRCL shall, on the occurrence of a Change in Law, give notice of such Change in Law to the Client in accordance with the provisions of this Article 22 as soon as it may be reasonably practicable.
- b) The notice served pursuant to this clause shall provide inter alia, precise details of the Change in Law and the effect thereof on IPRCL.

22.3 Consequences of Change in Law:

21 | Page

AGM (P) IPRCL
Ahmedabad.

मुख्य अभियंता
चीनव्याल पोर्ट ट्रस्ट
Chief Engineer
D. Dayal Port Trust

- a) In the event that a Change in Law renders exercise by the IPRCL of any of its material rights or performance by the IPRCL of any of its material rights and obligations, unless such obligation is waived by a person having the power to do so under this MOU impossible, the IPRCL may serve a notice for termination of this MOU (Termination Notice). Provided that prior to service of the Termination Notice, the parties shall consult in good faith for a period of 180 days to mitigate the material adverse impact of the change in Law. In the event the parties are unable to agree to changes to the MOU to mitigate the impact of the Change in Law during the 180 day period, either party may refer the matter to dispute resolution in which case the Termination Notice shall stand suspended until such matter has been resolved in accordance with Article 13.
- b) The parties hereby acknowledge and agree that IPRCL shall be entitled to serve a Termination Notice on the Client provided that the Change in Law results in physical or legal impossibility of performance of IPRCL's obligations or exercise of its rights under this MOU. The parties shall bear the respective impact of any economic consequences of Change in Law;

ARTICLE 23 – NOTICES

All notices under this MOU shall be in writing and are effective upon delivery to the applicable Party (whether by mail, fax, personal delivery or otherwise) at the address indicated below (or such other address as any Party may notify in writing to all the other Parties in accordance with the provisions of this MOU):

(i) If to IPRCL at:

Indian Port Rail & Ropeway Corporation Limited,
4th Floor, Nirman Bhavan,
Mumbai Port Trust Bldg.,
Mazgaon(E), Mumbai – 400 010.
Email: iprc@mumbai@gmail.com

(ii) If to Client at:

Chief Engineer,
Room No. 201,
Annex, Administrative Office, DFT
Gandhidham, kutch
PIN 370201

d
n
g
ce
nt

..202
al)

Mumbai
iprc.org

ARTICLE 24 – DELIVERY

Any notice, document or communication:

- i. given by hand against acknowledgement is deemed to be received at commencement of the Business Day next following delivery to the address of the receiving Party set out in Article 24.

AGM (P) IPRCL
Mumbai

मुख्य अभियंता
चीनवयाल पोर्ट ट्रस्ट
Chief Engineer
Mumbai Port Trust

- ii. sent by fax is deemed to be received at commencement of the Business Day next following receipt by the sending Party of an electronic confirmation of transmission of the notice to that addressee, which transmission is to be confirmed by a courier transmission date-marked the same day as the fax transmission it is confirming.

ARTICLE 25 – LANGUAGE

All notices required to be given by one Party to the other Party and all other communications, documentation and proceedings which are in any way relevant to this MOU shall be in writing and in English or Hindi language.

ARTICLE 26 – COUNTERPARTS

This MOU may be executed in two counterparts, each of which when executed and delivered shall constitute an original of this MOU.

ARTICLE 27- SIGNING OF MOU:

IN WITNESS HEREOF, the parties have hereunder signed the MOU, the date first written.

Name: Ashok Kumar Tiwari

Designation: AGM (Projects)

For Indian Port Rail&Ropeway Corporation Ltd:

Name: Suresh S. Patil

Designation: Chief Engineer

For Deendayal Port Trust

Witness:

1)  (Conditioned TPRELAB)

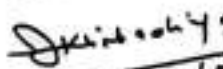
2)  (IPRCL/ADI J.A. Singh)

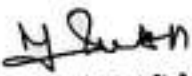
1)  (A.P. Firoz) XENCH)

2)  (H. K. Bhatnagar) (OPT)

ANNEXURE A**Project Cost Estimate Approved by DPT Board as Follows:**

Sr. No.	Head	Amount
A.	Civil Cost	Rs 208.56 Crores
B. Centages		
i)	Contingencies@2.8%	
ii)	IPRCL Charges@3%	Rs 5.21 Crores
iii)	Quality Control @0.5%	Rs 5.59 Crores
iv)	Road Safety @ 0.5%	Rs 0.93 Crores
v)	Supervision(independent Engineer) Charges @ 4%	Rs 0.93 Crores
vi)	Escalation Effective @7.75%	Rs 7.45 Crores
vii)	Maintenance Charges @ 1.75%	Rs 14.43 Crores
viii)	Utility shifting and other preconstruction activities (Per KM Rs 10,00,000)	Rs 3.26 Crores
	Total Cost of Centages	Rs 1.49 Crores
	Add 18 % GST on centages	Rs 39.29 Crores
	Total centages 'B' incl GST	Rs 7.07 Crores
	Total estimated Project Cost (A+B)	Rs 46.36 Crores
		Rs 254.92 Crores

Stages of payment of remuneration to charges against Sr. No. (ii) and (v) i.e. 7% will be as under:

Stages of Payments	% Payable
On Issue of LOA by IPRCL	20%
On Value of Work Done (Pro-rata)	70%
On Final Completion of Work	10%
Total	100%

Note: The charges against s.no (i), (iii), (iv), (vi), (vii), (viii) Shall be on actual expenditure basis.

**AGM (P) IPRCL
Ahmedabad.**

**मुख्य अभियंता
दीनदयाल पोर्ट ट्रस्ट
Chief Engineer
Deendayal Port Trust**

Annexure -I

DEENDAYAL PORT TRUST
(Erstwhile: KANDLA PORT TRUST)



Administrative Office I
Post Box NO. 50
GANDHIDHAM (Kutch),
Gujarat: 370 201.
Fax: (02836) 220050
Ph.: (02836) 220038

www.deendayalport.gov.in

EG/WK/5202 (D)/ Part 1147

Date: 08/02/2022

To,
The Additional Secretary & Director (Environment), Govt. of Gujarat,
Forest & Environment Department,
Block No.14, 8th floor, New Sachivalaya,
Gandhinagar - 382 010

Kind Attn.: Dr. S. K. Lal, Scientist C, MoEF&CC, GoI, Bhopal.

Sub: CRZ Clearance for the Construction of Interchange cum Road Over Bridge (ROB) at LC-236 [Kutch salt junction] on N.H-141 to Nehru gate of Kandla port, Gandhidham, Kutch proposed by M/s Deendayal Port Trust - **Compliance of stipulated conditions mentioned in the CRZ recommendations reg.**

Ref.: 1) GCZMA CRZ recommendation vides Letter No- ENV-10-2017-74-E dated 21.01.2018
2) DPT Letter No. EG-WK-5202(D)-PART-34 dated 02.07.2021

Sir,

It is requested to kindly refer the above cited reference for the said subject.

In this connection, it is to state that, the Gujarat Coastal Zone Management Authority vide above referred letter dated 21.01.2018 had recommended the subject project of Deendayal Port Trust. Subsequently, the SEIAA, Gujarat had accorded the Environmental & CRZ Clearance vide EC Letter No. SEIAA/GUJ/EC&CRZ/8(b)/728/2020 dated 19.06.2020 for the subject project.

DPT had signed an MOU with M/s IPRCL vide Certificate no. IN-GJ952233559268425 dated 9/06/2020 wherein IPRCL was appointed as the Project Implementation Agency for the project (Copy of MoU attached as Annexure A of the EC&CRZ Compliance).

Accordingly, as directed under Specific Condition No. 17 mentioned in the CRZ Clearance letter dated 21.01.2018 i.e. A six monthly report on compliance of the conditions mentioned in this letter shall have to be furnished by the DPT on a regular basis to this Department and MoEF&CC, GoI, please find enclosed herewith compliance report of the stipulated conditions along with necessary annexure submitted by M/s IPRRCL, for kind information & record please (Annexure I).

.....contd.

Further as per MoEF&CC, Notification S.O.5845 (E) dated 26.11.2018, stated that "In the said notification, in paragraph 10, in sub-paragraph (ii), for the words "soft copy" shall be substituted". Accordingly, we are submitting herewith soft copy of the same via e-mail.

This has the approval of the Chief Engineer, Deendayal Port Trust.

Thanking You.

Yours faithfully,

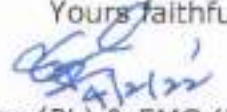
Superintending Engineer (PL) & EMC (I/c)
Deendayal Port Trust

Copy along with point wise compliance of stipulated conditions, to :

1) The Member Secretary,
State Level Environmental Impact Assessment Authority, Gujarat,
C/O, Gujarat Pollution Control Board
Sector- 10 A, Gandhinagar-382 010.
Email ID- seiaaguj@yahoo.com

2) Shri Prasoon Gargav,
Scientist E & Regional Director,
Central Pollution Control Board,
Parivesh Bhawan,
Opp. VMC Ward Office No.10, Subhanpura,
Vadodara - 390 023.
Email: prasoon.cpcb@nic.in

3) Smt. Urvashi Upadhyay,
Environment Engineer,
Unit Head, Kachchh ,
Gujarat Pollution Control Board,
Paryavaran Bhavan,
Sector 10A, Gandhinagar- 382 010.
Email-kut-uh-gpcb@gujarat.gov.in

4) The Regional Officer,
Gujarat Pollution Control Board,
Regional Office (East Kutch), Administrative Office Building,
Deendayal Port Trust, Gandhidham.
Email Id. ro-gpcb-kute@gujarat.gov.in

Subject: Point-wise Compliance Status Report for CRZ clearance for proposed project for Construction of Interchange cum Road Over bridge at N.H 141 to Nehru Gate of Deendayal Port Trust, Kandla, Dist: Kutch by Deendayal Port Trust-reg.

Ref No: - GCZMA CRZ recommendation vide Letter No- ENV-10-2017-74-E dated 21.01.2018

S. No.	CRZ Conditions	Compliance Status
SPECIFIC CONDITIONS		
1.	The DPT shall strictly adhere to the provisions of the CRZ Notification, 2011	IPRRCL (Project Implementation Agency) has submitted that it will adhere to all the provisions of CRZ Notification -2011.
2.	Necessary permissions from different departments/ agencies under different laws/ acts shall be obtained before commencing any activity including the construction activities	The Consent to Establish (CTE) from the GPCB had already been obtained vide CTE No. 89489 granted by the GPCB vide letter no. PC/CCA-KUTCH 1449/GPCB ID 56869 dated 03/10/2017 attached as Copy Annexure II of the EC Compliance . Copy of approved GAD enclosed as Annexure III of the EC Compliance .
3.	The DPT shall ensure that adequate culvert/passages are provided during construction of road and there shall be no obstruction of free flow of water.	IPRCL has submitted that a total of 15 culverts have been provided by the design consultant and it is being ensured that there is no obstruction to free flow of water. (Copy of GAD of Culverts attached as Annexure VI of the EC Compliance).
4.	The DPT shall ensure that there shall not be any blockage of creek and free flow of water is maintained	IPRRCL (Project Implementation Agency) has submitted that it has been ensuring that no creeks or flow of water are being blocked due to any activity at the project site and the pipe culverts will be constructed at required location in creek for free flow of water.
5.	The DPT shall construct settling ponds and the installation of the oil receptor to prevent the entry of the surface run-off from fuel and other contaminants into the wells and other surface bodies along the corridor.	IPRCL has submitted that there are no wells in the project area and it will be observed that there is no spillage of fuel at project area.
6.	No vehicle or equipments shall be parked or re fuelled near the water-body, so as to avoid contamination from fuel and lubricants	IPRCL has submitted that Vehicles and equipments are parked and refuelled at the site office area, and there is no sweet water

Jt. GENERAL MANAGER (P)
IPRCL/GANDHIDHAM

S. No.	CRZ Conditions	Compliance Status
		body near the site office.
7.	Hot mix plants/concrete mix plants shall be located and operated in such a way that there shall be no Air pollution.	IPRCL has submitted that only GPCB approved Hot-mix plants/Concrete mix plants is being allowed to operate for the project. IPRCL obtained the CCA from GPCB for the HMP vide its letter no. 415000 dated 15/06/2017. (Copy of CCA attached as Annexure VII of the EC Compliance).
8.	The DPT shall ensure that the quarry works, from which they will purchase raw materials, shall conform to the norms and having necessary clearances from the respective authorities.	IPRCL has submitted that the quarry works, from which raw materials are purchased, conforms to the norms and has necessary clearances from the respective authorities.
9.	The DPT shall make MOU with raw material supplier quarry/hot mix plants e.t.c in such a way that they will comply with all the terms and conditions mentioned in the CCA/NOC issued by the Gujarat Pollution Control Board.	IPRCL has submitted that the raw materials are being purchased by the contractors directly hence M.O.U by DPT with supplier is not required. However, conditions mentioned in NOC by GPCB are being complied with.
10.	The DPT shall explore the possibility for using the fly ash @ 5%-10% to comply with the Fly Ash Notification.	IPRCL has submitted that Fly ash is being used for ready mix concrete work.
11.	The DPT shall make sure that all the wastes arising from the project shall be disposed of at identified sites in environmentally sound manner.	IPRRCL has submitted that solid waste generated from construction site & labor camp are being disposed off as per solid waste management Rules-2016 by IPRRCL.
12.	There shall no discharge of any kind of wastewater/sewage/effluent into the creek/sea or in the CRZ areas.	IPRRCL has submitted that there is no discharge of any kind of wastewater/sewage/effluent into the creek/sea or in the CRZ areas.
13.	The DPT shall implement all the suggestions/recommendations given in the EIA report by their consultant M/s. Mantech Consultant Pvt. Ltd.	All the suggestions/ recommendations given in the EIA report by consultant are being implemented by IPRRCL (Project Implementation Agency).
14.	No ground water shall be taped to meet with the water requirements during the construction and/or	IPRCL has submitted that the fresh water requirement during the construction phase is being met with Private Tanker Supplying

 Jt. GENERAL MANAGER (P)
 IPRCL/GANDHIDHAM

S. No.	CRZ Conditions	Compliance Status
	operation phases.	agency. It is ensured that no ground water is being tapped during the construction phase.
15.	The DPT shall not discharge any kind of waste including the construction debris into the river/estuary or into the CRZ areas.	IPRRCL has submitted that there is no discharge of any kind of wastewater/sewage/effluent into the creek/sea or in the CRZ areas is being done.
16.	The DPT shall ensure that the construction camps are kept outside the CRZ areas and the construction labour are provided with adequate amenities like drinking water, fuel, sanitation etc. to ensure that the existing environmental condition is not deteriorated by them.	IPRRCL has submitted that it has provided adequate amenities like drinking water, fuel, sanitation, etc. to the construction labourers to ensure that the existing environmental condition is not deteriorated by them.
17.	The DPT shall regularly submit the half-yearly compliance report on the conditions stipulated by this department/SEIAA	IPRRCL shall submit the Compliance report periodically.
18.	Any other conditions that may be stipulated by this department/SEIAA from time to time for environmental protection/management purpose.	Point Noted for compliance

 Jt. GENERAL MANAGER (P)
 IPRCL/GANDHIDHAM

Annexure -II

DEENDAYAL PORT TRUST
(Erstwhile: KANDLA PORT TRUST)



Administrative Office Building
Post Box NO. 50
GANDHIDHAM (Kutch).
Gujarat: 370 201.
Fax: (02836) 220050
Ph.: (02836) 220038

www.deendayalport.gov.in

No:- EG/WK/4684(EC)/PartVII/148

Date: 08/08/2022

To,
Smt. Urvashi Upadhyay,
Environment Engineer,
Kutch Unit Head,
Gujarat Pollution Control Board,
Paryavaran Bhavan,
Sector 10A, Gandhinagar-
382 010
Email-kut-uh-gpcb@gujarat.gov.in

Sub: Environment & CRZ Clearance for the Construction of Interchange cum Road Over Bridge (ROB) at LC-236 [Kutch salt junction] on N.H-141 to Nehru gate of Kandla port, Gandhidham, Kutch proposed by M/s Deendayal Port Trust- **Compliance of Conditions mentioned in the NoC/CTE reg.**

Ref.: 1) GPCB CTE-89489 vide Letter No- PC/CCA-KUTCH-1449/GPCBID-56869 dated 03.10.2017
2) DPT Letter no. EG-WK-5202(D)-PART-35 dated 02.07.2021

Sir,

It is requested to kindly refer above cited references for the said subject.

In this connection, it is to state that, vide above referred Letter No- PC/CCA-KUTCH-1449/GPCBID-56869 dated 03.10.2017 had granted NoC/CTE with validity up to 02.10.2022.

DPT had signed an MOU with M/s IPRCL vide Certificate no. IN-GJ952233559268425 dated 9/06/2020 wherein IPRCL was appointed as the Project Implementation Agency for the project (Copy of MoU attached as Annexure A of the EC&CRZ Compliance).

Now, please find enclosed herewith, compliance report of conditions stipulated in CTE order (period **June to November 2021**) along with necessary enclosures as **Annexure I**, submitted by IPRCL, for your kind perusal & record please.

Further, as per the MoEF&CC, Notification S.O.5845 (E) dated 26.11.2018, stated that "**In the said notification, in paragraph 10, in sub-paragraph (ii), for the words "hard and soft copies" the words "soft copy" shall be substituted**". Accordingly, we are submitting herewith soft copy of the same via e-mail ID kut-uh-gpcb@gujarat.gov.in.

This has approval of the Chief Engineer, Deendayal Port Trust.

Yours faithfully,

SE (PL) & EMC (I/c)
Deendayal Port Trust

.....Cont.....

Copy to : Regional Officer, (Kutch East)
Gujarat Pollution Control Board,
Room No. 215 - 217, Regional Office,
2nd Floor, A.O Building,
Deendayal Port Trust,
Gandhidham (Kutch)- 370 201
Email Id. ro-gpcb-kutch@gujarat.gov.in

Subject: Point-wise Compliance Status Report for CTE for proposed project for Construction of Interchange cum Road Over bridge at N.H 141 to Nehru Gate of Deendayal Port Trust, Kandla, Dist: Kutch by Deendayal Port Trust-reg.

Ref No: - GPCB CTE-89489 vide Letter No- PC/CCA-KUTCH-1449/GPCBID-56869 dated 03.10.2017

DPT had signed an MOU with M/s IPRCL vide Certificate no. IN-GJ95223355926842S dated 9/06/2020 wherein it was IPRCL was appointed as the Project Implementation Agency for the project. **(Copy of MoU attached as Annexure A of).**

S. No.	CTE Conditions	Compliance Status
SPECIFIC CONDITIONS		
1.	This CTE 89489 is granted subject to the condition that you shall not stall any construction activities prior to obtaining of EC and CRZ clearance from competent authority for their interchange cum road over bridge at 14.892 Km.	EC & CRZ Clearance has been issued by SEIAA, Gujarat vide EC Letter No. SEIAA/GUJ/ EC&CRZ/ 8(b)/728/2020 dated 19/06/2020. Date of start of commencement of the project 01/10/2020.
2.	No ground water shall be used without obtaining prior approval from the authority.	IPRCL has submitted that the fresh water requirement during the construction phase is being met with Private Tanker Supplying agency. It is ensured that no ground water is being tapped during the construction phase.
3.	Unit Shall adhere to all condition of ToR issued by SEIAA vide order No. SEIAAGUJ/ToR/8(b)/471/2017 dated 29.4.2017.	IPRCL shall adhere to all condition of ToR issued by SEIAA vide order No. SEIAAGUJ/ToR/8(b)/471/2017 dated 29.4.2017.
1.	CONDITIONS UNDER WATER ACT 1974:	
1.1	The generation of effluent construction operators shall not exceed of 16 kl/day and water shall be used for sprinkling purpose by dust suppression purpose.	IPRCL has submitted that Water sprinkling is being done in vulnerable area on need basis.
1.2	The sewage shall be disposed through septic tank.	IPRCL has submitted Sewage generated during the construction phase is being treated in septic tank.
2.	CONDITIONS UNDER AIR ACT 1981:	
4.1	There shall be no flue gas emission and process emission from construction activity and other ancillary emission.	IPRCL has submitted that no flue gas emission and process emission from construction activity and other ancillary

Jt. GENERAL MANAGER (P)
IPRCL/GANDHIDHAM

S. No.	CTE Conditions	Compliance Status																				
		emission.																				
4.2	<p>The concentration of the following parameters in the ambient air within the premises of the industry shall not exceed the limits specified hereunder as per national Ambient Air Quality Emission Standards issues by Ministry of Environment, Forest and Climate Change dated 16th November, 2009.</p> <table border="1" data-bbox="279 638 821 996"> <thead> <tr> <th>No.</th> <th>Pollutant</th> <th>Time Weight Average</th> <th>Concentration in Ambient Air in $\mu\text{g}/\text{M}^3$</th> </tr> </thead> <tbody> <tr> <td>1.</td> <td>SO₂</td> <td>Annual 24 Hrs</td> <td>50 80</td> </tr> <tr> <td>2.</td> <td>NO₂</td> <td>Annual 24 Hrs</td> <td>40 80</td> </tr> <tr> <td>3.</td> <td>PM₁₀</td> <td>Annual 24 Hrs</td> <td>60 100</td> </tr> <tr> <td>4.</td> <td>PM_{2.5}</td> <td>Annual 24 Hrs</td> <td>40 60</td> </tr> </tbody> </table>	No.	Pollutant	Time Weight Average	Concentration in Ambient Air in $\mu\text{g}/\text{M}^3$	1.	SO ₂	Annual 24 Hrs	50 80	2.	NO ₂	Annual 24 Hrs	40 80	3.	PM ₁₀	Annual 24 Hrs	60 100	4.	PM _{2.5}	Annual 24 Hrs	40 60	IPRCL has submitted that concentration of the various parameters in the ambient air within the premises of the construction camp does not exceed the limits specified hereunder as per national Ambient Air Quality Emission Standards.
No.	Pollutant	Time Weight Average	Concentration in Ambient Air in $\mu\text{g}/\text{M}^3$																			
1.	SO ₂	Annual 24 Hrs	50 80																			
2.	NO ₂	Annual 24 Hrs	40 80																			
3.	PM ₁₀	Annual 24 Hrs	60 100																			
4.	PM _{2.5}	Annual 24 Hrs	40 60																			
a.	The applicant shall provide portholes, ladder, platform etc. at chimney(s) for monitoring the air emissions and the same shall be open for inspection to/and for use of Board's staff. The chimney(s) attached to various source of emission shall be designed by numbers such as S-1, S-2, etc. and these shall be painted/displayed to facilitate identification.	IPRCL has submitted that this segment is not applicable as it is a road project.																				
b.	The concentration of Noise in Ambient Air within the premises of industrial unit shall not exceed following levels: Between 6 A.M. and 10 P.M.: 75 dB (A) Between 10 P.M. and 6 A.M.: 70 dB (A)	IPRCL has submitted that concentration of Noise in Ambient Air within the premises of construction camp does not exceed the prescribed levels.																				
CONDITIONS UNDER HAZARDOUS WASTE																						
5.1	Applicant shall have to comply with provisions of Hazardous Waste (Management, Handling & Trans-boundary Movement Rule-2016)	IPRCL shall comply with provisions of Hazardous Waste (Management, Handling & Trans-boundary Movement Rule-2016)																				
5.2	The applicant shall obtain membership of common TSDF site for disposal of Hazardous Waste (Management, Handling & Trans-boundary Movement Rule-2016)	IPRCL has submitted that necessary permission shall be obtained as and when required.																				
5.3	The applicant shall obtain membership of common Hazardous waste incinerator for disposal of incinerable waste.	IPRCL has submitted that necessary permission shall be obtained as and when																				

 J. GENERAL MANAGER (P)
 IPRCL/GANDHIDHAM

S. No.	CTE Conditions	Compliance Status
		required.
5.4	The applicant shall provide temporary storage facilities for each type of hazardous waste as per Hazardous Waste (Management, Handling & Transboundary movement) Rule-2016.	IPRCL has noted the points for compliance.
GENERAL CONDITION		
6.1	Unit shall develop greenbelt on road side as per the CPCB guidelines. However if the adequate land is not available with the premises, the unit shall tie up with local agencies like gram panchayat, school, social forestry office etc. for the plantation at suitable open land in nearby locality and submit an action plan of plantation for next three years to GPCB.	IPRCL has submitted that Horticulture has been proposed in the median and greenbelt development shall be done.
6.2	In case of change of ownership/management the name and address of the new owners/partners/ directors/ proprietor should immediately be intimated to the Board.	IPRCL has noted the points for compliance.
6.3	The applicant shall however, not without the prior consent of the Board bring into use any new or altered outlet for the discharge effluent or gaseous emission or sewage waste from the proposed industrial plant. The applicant is required to make applications to the Board for this purpose in the prescribed forms under the provisions of the Water Act 1974, the Air Act 1981 and the Environment (Protection) Act, 1986.	IPRCL has noted the points for compliance.
6.4	The overall noise level in and around the plant area shall be kept well within the standards by providing noise control measures including engineering control like acoustic insulation hoods, silencers, enclosures etc. on all sources of noise generation. The ambient noise level shall conform to the standards prescribed under the Environment (Protection) Act, 1986 & Rules.	IPRCL has submitted that overall noise level in and around the construction camp area has been kept well within the standards by providing various noise control measures.
6.5	Applicant is required to comply with the manufacturing, storage and Import of Hazardous chemicals Rules-1989 formed under the Environment (protection) Act 1986.	IPRCL has noted the points for compliance.



 Jt. GENERAL MANAGER. (P)
 IPRCL/GANDHIDHAM

S. No.	CTE Conditions	Compliance Status
6.6	If it is established by any competent authority that the damage is caused due to their industrial activities to any person or his property in that case they are obliged to pay the compensation as determined by the competent authority.	IPRCL has noted the points for compliance.
6.7	Applicant shall have to comply with all guidelines, Directive issued/ being issued by MoEF/CPCB/DoEF from time to time.	IPRCL has noted the points for compliance.
6.8	Applicant shall not use/withdraw ground water either during construction and /operation phase.	IPRCL has submitted that the fresh water requirement during the construction phase is being met with Private Tanker Supplying agency. It is ensured that no ground water is being tapped during the construction phase.
6.9	Environmental cell shall be setup and shall be responsible for the total Environmental management.	All the environment related aspects of the project during construction and operational phase are being supervised by Project Implementation Agency. DPT has signed an MOU with M/s IPRCL vide Certificate no. IN-GJ95223355926842S dated 9/06/2020 wherein it was IPRCL was appointed as the Project Implementation Agency for the project.
6.10	Monitoring in respect to Air, water, Noise level shall be carried out and results shall be submitted to this Board on quarterly basis.	IPRCL has noted the points for compliance.

 J. GENERAL MANAGER (P)
 IPRCL/GANDHIDHAM

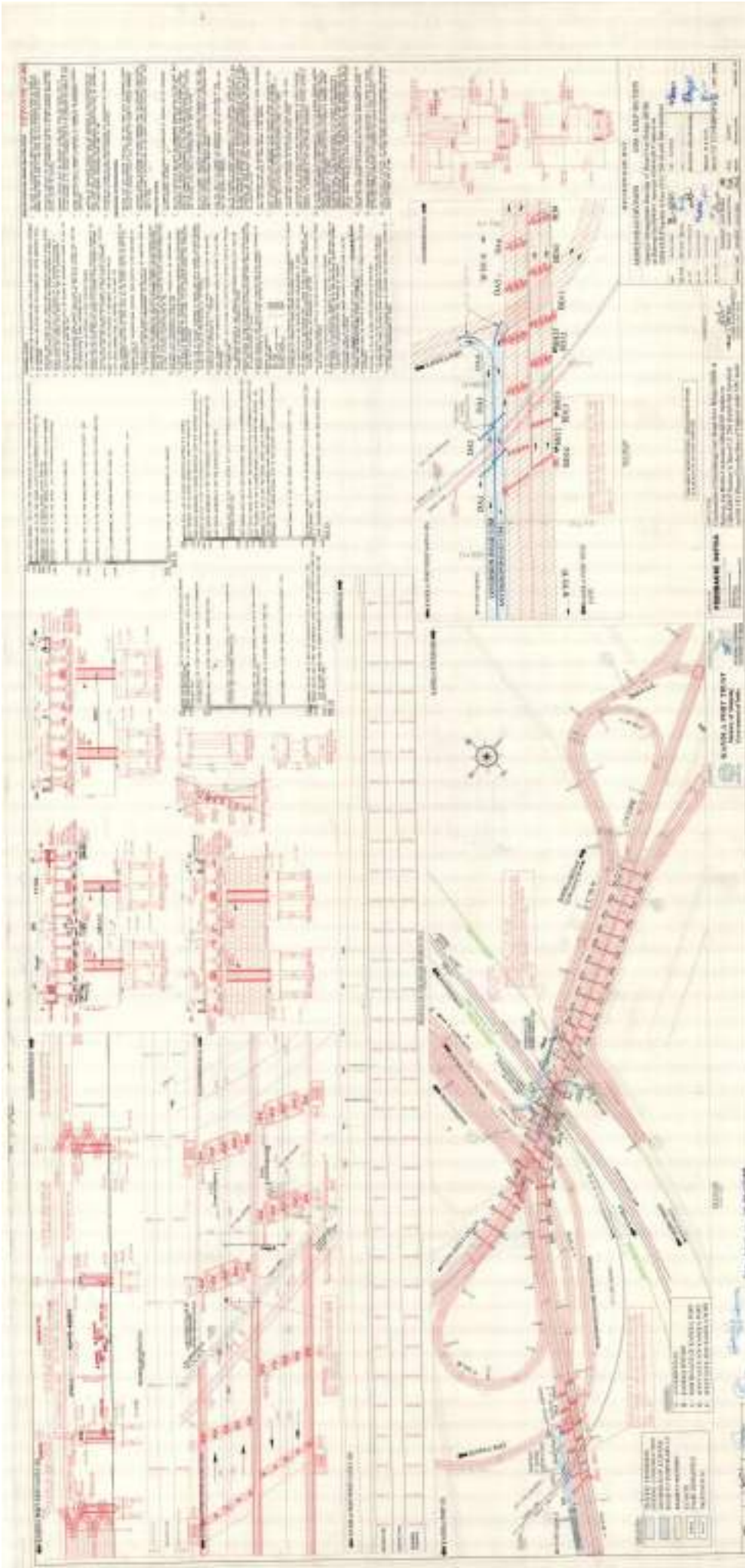
Annexure -III

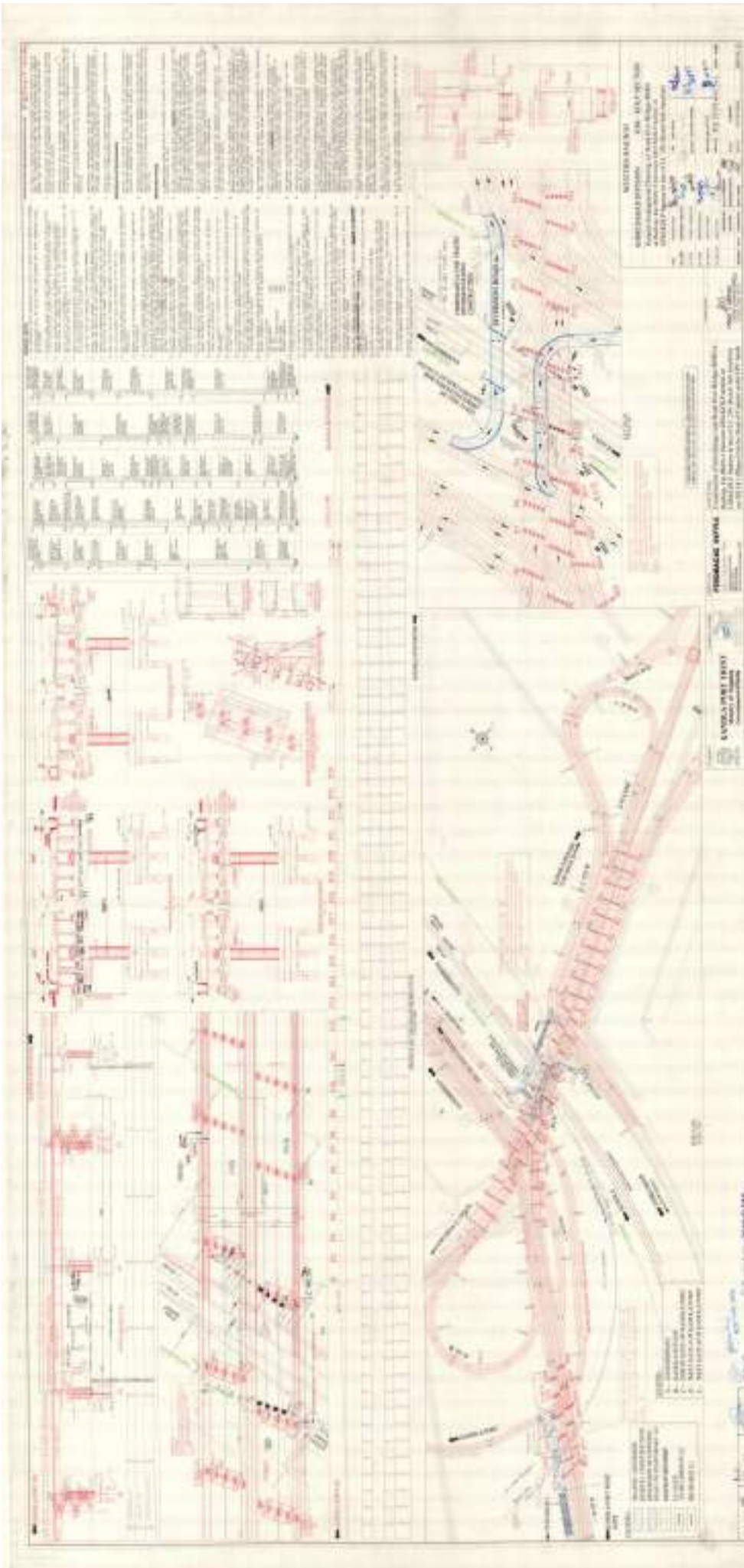



Annexure -IV



इंडियन पोर्ट रेल कॉर्पोरेशन लिमिटेड
(भारत सरकार का उपक्रम)
Indian Port Rail Corporation Ltd.
(A Government of India Enterprise)
CIN No: U60300DL2015GOI282703



Construction of Interchange cum Road Over Bridge (ROB) at LC 236 (Kutch Salt - Junction) on NH 141 (Phase- I) in the State of Gujarat under EPC mode.

EPC Contractor:

Niraj - Patel JV

BBZ S 60, "NEELKANTH", ZANDA CHOWK,
GANDHIDHAM, KUTCH, GUJARAT - 370201.



Design of ROB Super Structure @ Ch.0+639

Sep 2020

Design Consultants:



Nivedita Consultants

B - 98, Sector - A, Sanik Vihar Colony, Nandanagar, Kurraghat, Gorakhpur -
273008 (UP) Phone: +91-0124-4054562; email: nivcons@gmail.com

AUTHORITY:

इंडियन पोर्ट रेल कॉर्पोरेशन लिमिटेड
 (ए गवर्नमेंट ऑफ इंडिया एंटरप्राइज)
 Indian Port Rail Corporation Ltd.
 (A Government of India Enterprise)
 CIN No. U60300DL2015OC1282703

**PROJECT: Construction of Interchange cum ROB**

Construction of Interchange cum Road Over Bridge (ROB) at LC 236 (Kutch salt junctio) on NH 141 (Phase-1) in the state of Gujrath under EPC mode.

EPC CONTRACTOR:

M/S NIRAJ-PATEL JV

BBZ S 60, "Neelkanth" Zanda chowl, Gandhidhsm, Kutch, Gujrat- 370201

THIRD PARTY PROOF CONSULTANT:

Indian Institute of Technology (IIT) Varanasi
 IIT-BHU, Banaras Hindu University Campus,
 Uttar Pradesh 221005

PROOF CONSULTANT:

M/s Nitya Nayra Civil Solution PVT. LTD

1/70, TF-1, MIG SEC-1, Vasundhra, Ghaziabad - 201 012, Uttar Pradesh, India

TITLE OF DOCUMENT:

Design of ROB Super structure at CH:0+639.1

Doc. Number:	KUT-SUP STR-ROB-RLY-CH'0+639.1-DN-01	Prepared By:	CN
Rev. No:	R0	Checked By:	NK
Date:	29/8/2020	Approved By:	NK

Date:	Rev No.	Revision	By
29/8/2020	R0	For Review and Approval	CN

DESIGN CONSULTANT:

email: nivcons@gmail.com



Nivedita Consulting

B - 98, Sector - A, Sanik Vihar Colony, Nandanagar, Kunraghat,
 Gorakhpur - 273008 (UP) Phone: +91-0124-4054562,

Project:	Construction of Interchange cum ROB	 Nirvaha Consultants
Doc. Title	Design of ROB Super structure at CH:0+639.1	
Doc. no.	KUT-SUP STR-ROB-RLY-CH"0+639.1-DN-01	Rev. R0

Design of Super Structure
Table of Contents

Sl. No.	Title	Page No.		
1	Design of PSC I Girder and Diaphragm	1	-	383
2	Design of RCC I Girder and Diaphragm	389	-	486
3	Design of RCC Deck Slab	487	-	510

Design of PSC I - Girder

Project	Construction of Interchange cum ROB	 Nivedita Consultants		
Proc. Title	Design of ROB Super structure at CH+639.1			
Doc. no.	KUT-SUP STR-ROB-RLY-CH+639.1-DN-01			
		Rev.	-	RO

SALIENT FEATURES OF THE BRIDGE DECK:

Slew angle	=	20 deg.
Span c/c of Exp. J	=	30.0 m
Exp. Gap	=	42.6 mm
c/L of brg to c/L of exp. J	=	0.69 m
Span c/c of brg	=	28.617 m (SK)
Overall span	=	29.957 m (SK)
Overhang beyond c/L brg	=	0.670 m (SK)
Thickness of End Cross-Girder	=	0.851 m (SK)
Thickness of Intermediate Cross-Girder	=	0.519 m (SK)
Girder overhang beyond c/l brg	=	0.000 m
Overall Length of Girder	=	28.10 m (SK)
c/L of temporary brg. from face of girder	=	0.65 m
c/L of permanent brg. to face of end cross girder	=	0.426 m
Overall carriageway width	=	15.4 m
Wearing Coat Thickness	=	65 mm
Depth of Precast Beam	=	1.900 m
Thickness of Cast-in-situ deck	=	0.250 m
Overall depth Beam +slab	=	2.150 m
c/c of girder (transverse direction)	=	3.5 m
Nos. of Girder	=	4 Nos.
Deck cantilever in transverse direction	=	1.45 m
Density of Concrete	=	2.5 t/m ³
Size of bearing	=	0.600 x 0.600 m (Long) (Trans)

PROPORTIONING OF PRECAST BEAM

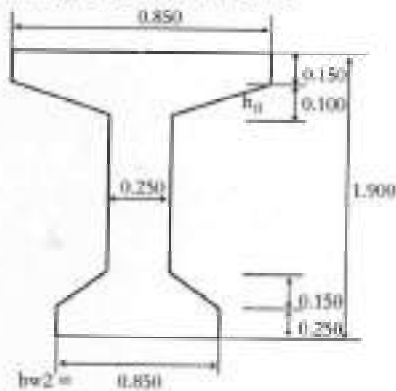

Section at Mid Span

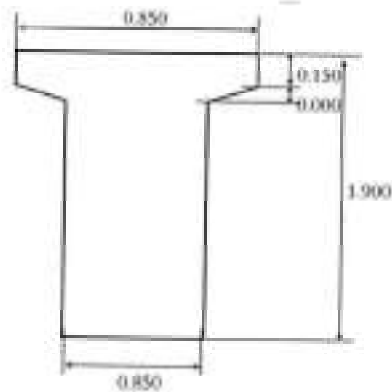

Section at Support

Project	Construction of Interchange cum ROB	Nivedita Consultants
Doc. Title	Design of ROB Super structure at CH:0+639.1	
Doc. no.	RUT-SUP STR-ROB-RLY-CH*0+639.1-DN-01	
Rev.	-	80

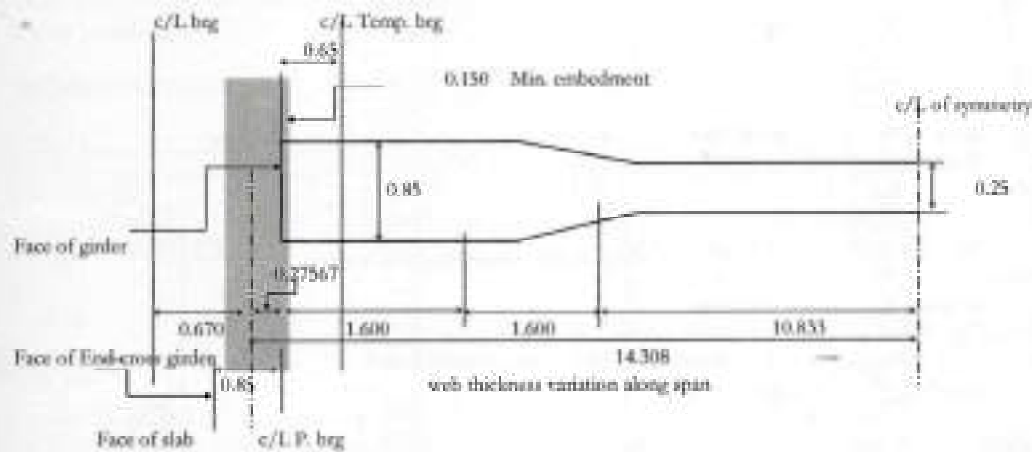

Web Thickening

Section At	Face	Backing	c/L. beg.	c/L. beg.	T ₁	defl	L/8	15	2L/8	3L/8	4L/8
Dist. From c/L. Permanent beg. (m)	0.00	0.15	0.00	0.00	1.60	1.81	3.58	3.20	7.15	10.73	14.31
Dist. From face of girder (m)	0.00	-0.15	0.00	0.00	1.60	1.81	3.51	3.20	7.02	10.54	14.05
Dist. From jacking point (m)	-0.15	0.00	0.28	0.28	1.45	1.66	3.36	3.05	6.87	10.39	13.90
Dist. From c/L. temp. beg. (m)	0.00	0.15	-0.65	-0.65	0.95	1.16	2.86	2.55	6.37	9.89	13.40
tw	m.	0.85	0.85	0.85	0.85	0.78266	0.250	0.3381832	0.25	0.25	0.25

Overall depth of composite girder = 2.130 m
 d_{cr} = 1.811 * /Assumed 0.85 times of overall depth

MATERIAL USED :

Grade of Reinforcement = Fe 500
 f_yk = 500 Mpa
Modulus of Elasticity E_s = 200000 Mpa

Cast in situ slab = M 40
 f_{ck} = 40 Mpa
 f_{cm} = 50 MPa
 E_{cm} = 33000 MPa

Precast Beam = M 45
 f_{ck} = 45
 f_{cm} = 55 MPa
 E_{cm} = 34000 MPa

$f_{ck,0.05}$ = Characteristic axial tensile strength of concrete = 2.5 MPa

ANALYSES ASSUMPTION

Environmental parameters

Relative humidity = 57 %
Exposure condition = SEVERE

Design Director
Niraj Patel JV



MANAGER (P) IPRCL
GANDHIDHAM

Proof Checked
K. K. Pathak
Prof. K. K. Pathak
Department of Civil Engineering
Indian Institute of Technology
Banaras Hindu University
Varanasi-221005

Project:	Construction of Interchange cum ROB	 Nivedita Consultants
Doc. Title	Design of ROB Super structure at CHD# 639.1	
Doc. no.	RUT-SUP STR-ROB-RLY-CH#0+639.1-DN-01	
Rev.		RD

TEMPERATURE

Coefficient of thermal expansion = 1.20-05 /°C

FOR PRECAST BEAM

Modular of Elasticity

For short Term loading $E_{cm} = 34000 \text{ Mpa}$

For long Term loading $E_{cm}' = E_{cm} / (1+\phi)$

ϕ = Creep coefficient

Creep

Cross-sectional Area $A_c = 1.51 \text{ m}^2$ (Composite Outer Girder at mid span considered)

Perimeter in contact with atmosphere = 8.56 m

Nominal size ho $2A_c/u = 352 \text{ mm}$

ϕ (s) = 1.53 (Refer Appendix B)

ϕ (s) = 1.68 % (Increased by 10% on the conservative side)

$E_{cm}' = 12682.7 \text{ N/mm}^2$

SERVICEABILITY LIMIT STATE:

Rare Combination

Max permissible Stress in Concrete = $0.48 \cdot f_{ck}(t)$

Max permissible tensile Stress in Concrete

$f_{ctm} = -3.3 \text{ Mpa} = f_{ctm}$ (mean tensile strength)

Quasi permanent Combination

Max permissible Stress in Concrete = $0.36 \cdot f_{ck}(t)$

Max permissible Stress in Steel = $0.8 \cdot f_{yk} = 400 \text{ Mpa}$

Permissible crack width $w_{lim} = 0.2 \text{ mm}$

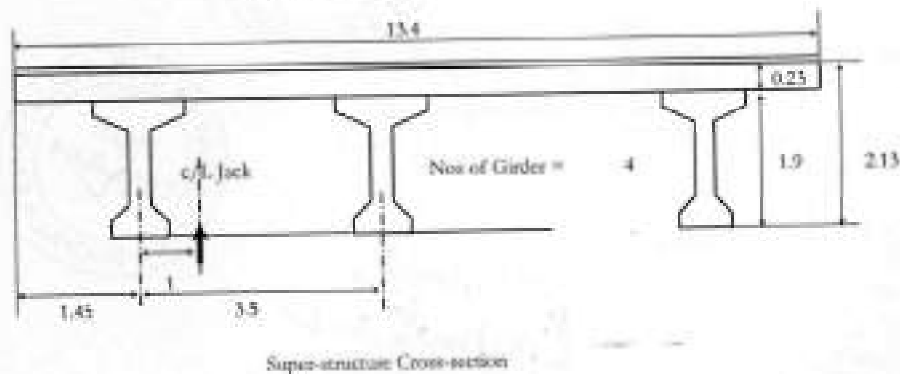
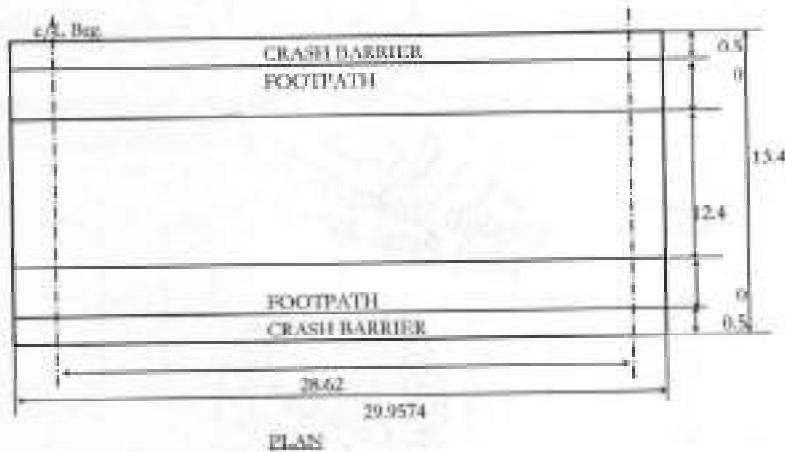

Project:	Construction of Interchange cum ROB	 Nredita Consultants
Doc. Title:	Design of ROB Super structure at CH:0+639.1	
Doc. no.:	KUT-SUP STR-ROB-BLY-CH:0+639.1-DN-01	Rev. RO

PROPERTY CALCULATION OF PRECAST BEAM:

Density of concrete = 2.5 t/m³

INNER/ OUTER GIRDER:

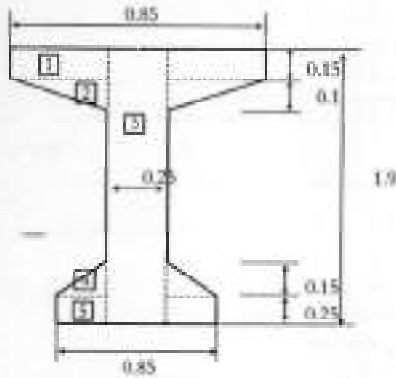

Section at Mid Span

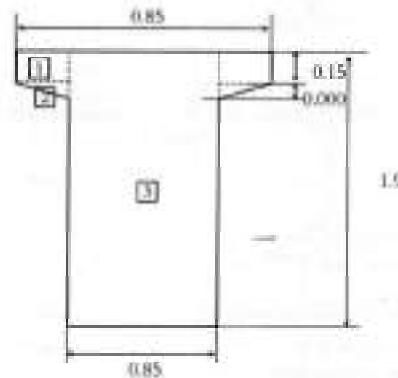

Section at Support

Section Property At Mid Span

Element No.	Factor	B	D	Nos.	A	cg _y	I _{zz}	cg _x	I _{yy}
		m	m		m ²	m	m ⁴	m	m ⁴
1	1	0.300	0.15	2	0.0900	0.075	0.080	0.275	0.00748
2	0.5	0.300	0.1	2	0.0300	0.18333	0.021	0.225	0.00167
3	1	0.25	1.9	1	0.475	0.95	0.145	0	0.00247
4	0.5	0.3	0.15	2	0.045	1.60	0.015	0.275	0.00363
5	1	0.3	0.25	2	0.150	1.78	0.087	0.225	0.00872
Total					0.7900	1.015	0.348		0.0240

UDL = 0.790 x 2.5 = 1.98 t/m

Section Property At Support Section

Element No.	Factor	B	D	Nos.	A	cg _y	I _{zz}	cg _x	I _{yy}
		m	m		m ²	m	m ⁴	m	m ⁴
1	1	0.000	0.15	2	0.000	0.075	0.000	0.425	0
2	0.5	0.000	0.00	2	0.0000	0.15	0.000	0.425	0
3	1	0.85	1.9	1	1.615	0.95	0.486	0	0.09724
Total					1.615	0.850	0.486		0.0972

UDL = 1.615 x 2.5 = 4.04 t/m

Section At	unit	Face	locking	c/L beg.	c/L beg.	d/eff	T _c	L/8	TS	3L/8	3L/8	4L/8
Dist. From c/L beg.	m	0	0.15	0	0	1.8105	1.600	3.577	3.200	7.154	10.731	14.308
web width	bw	0.85	0.85	0.85	0.85	0.78266	0.85	0.25	0.35818	0.25	0.25	0.25
Area	A	1.615	1.615	1.615	1.615	1.522	1.615	0.790	0.911	0.790	0.790	0.790
I _{zz}	m ⁴	0.486	0.486	0.486	0.486	0.470	0.486	0.348	0.368	0.348	0.348	0.348
I _{yy}	m ⁴	0.097	0.097	0.097	0.097	0.089	0.097	0.024	0.035	0.024	0.024	0.024
y _b	m	0.950	0.950	0.950	0.950	0.943	0.950	0.685	0.695	0.685	0.685	0.685
x _b	m	0.950	0.950	0.950	0.950	0.957	0.950	1.015	1.005	1.015	1.015	1.015

Nredita
Design Director
Niraj Patel JV



K. K. Pathak
MANAGER (SP) / IPRCL
GANDHIDHAM

Proof Checked
K. K. Pathak
Prof. K. K. Pathak
Department of Civil Engineering
Indian Institute of Technology
Banaras Hindu University
Varanasi-221005

Project:	Construction of Interchange cum ROB	 Nivedita Consultants
Doc. Title	Design of ROB Super structure at CH+639.1	
Doc. no.	KUT-SUP STR-ROB-RLY-CH+639.1-DN-01	
Rev.		RO

EFFECTIVE WIDTH CALCULATION:

$$\text{Effective Span } \ell = \text{Min} \begin{cases} \text{Distance from bearing to bearing} \\ \text{Clear distance b/w supports} + \text{Effective depth} \end{cases}$$

$$\text{Bearing Size in Longitudinal dir}^* = 0.6 \text{ m}$$

$$\ell = \text{Min} \left\{ \begin{array}{l} 28.6166 \\ 28.0166 \end{array} \right. + 1.8105 \text{ } \left. \begin{array}{l} \text{+ / (Effective depth assumed 0.85 times} \\ \text{of Overall depth)} \end{array} \right.$$

$$\ell = 28.617 \text{ m}$$

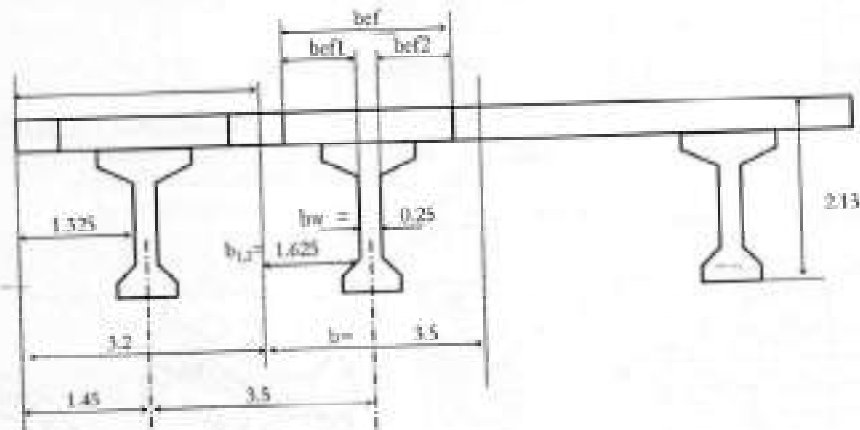

beff CALCULATION FOR INNER GIRDER:

$$b_{1,2} = 1.625$$

$$beff_{1,2} = \text{Min} \begin{cases} 0.2 b_1 + 0.1 \ell = 3.2 \text{ m} \\ 0.2 \ell = 5.72331 \text{ m} \end{cases}$$

$$beff_{1,2} = 3.18666 \text{ m}$$

$$beff = \text{Min} \left\{ \begin{array}{l} \sum beff_j + bw = 6.62331 \text{ m} \\ b = 3.5 \text{ m} \end{array} \right.$$

$$\boxed{beff = 3.5 \text{ m}}$$

beff CALCULATION FOR OUTER GIRDER:

$$b_1 = 1.325 \text{ m}$$

$$b_2 = 1.63 \text{ m}$$

$$beff_1 = \text{Min} \begin{cases} 0.2 b_1 + 0.1 \ell = 3.1 \text{ m} \\ 0.2 \ell = 5.72331 \text{ m} \end{cases}$$

$$beff_1 = 3.12666 \text{ m}$$

$$beff_2 = \text{Min} \begin{cases} 0.2 b_2 + 0.1 \ell = 3.2 \text{ m} \\ 0.2 \ell = 5.7 \text{ m} \end{cases}$$

$$beff_2 = 3.18666 \text{ m}$$

$$beff = \text{Min} \left\{ \begin{array}{l} \sum beff_j + bw = 6.56331 \text{ m} \\ b = 3.2 \text{ m} \end{array} \right.$$

$$\boxed{beff = 3.2 \text{ m}}$$

Project	Construction of Interchange cum ROB			Trendra Consultants	
Doc. Title	Design of ROB Super structure at CH:0+639.1			Rev.	RO
Doc. no.	KUT-SUP STR.-ROB-RELY-CH"0+639.1-DN-01			-	-

DI CHECK FOR SHEAR: (IRC 112 / clause 10.3.2 (c))

Check of Shear Reinforcement Requirement

Load comb.	V_{req}	β	βV_{ED}	d	bw	$k = \text{Min} [1 + \sqrt{300/d}, 2]$	A_{sl}	$p1 = \text{Min} [A_{sl}/bw \cdot d, 0.02]$	$V_{min} = 0.031 k^{1/2} f_{ck}^{1/2}$	σ_{cp}	$V_{max} = \text{Max} [(0.12 k + (90 p1 f_{ck})^{0.11}) \cdot bw \cdot d, (V_{min} + 0.15 \sigma_{cp}) \cdot bw \cdot d]$	Check
T	T	T	T	mm	mm	mm	mm ²			Mpa	Tonne	
Cantilever Portion												
Cantilever (Girder Top Flange Face)	10.06	1	10.06	179	1000	2.000	1330.557	0.0074	0.555	0	12.2251	No Shear reinf. Required
Cantilever (Girder Web Face)	13.98	1	13.98	429	1000	1.683	1330.557	0.0031	0.428	0	18.4751	No Shear reinf. Required
Intermediate supports												
Girder Top Flange Face	11.17	1	11.17	179	1000	2.000	1330.557	0.0074	0.555	0	12.2251	No Shear reinf. Required
Girder web Face	17.41	1	17.41	429	1000	1.683	1330.557	0.0031	0.428	0	18.4751	No Shear reinf. Required
Intermediate span												
Intermediate Mid Span	8.55	1	8.55	179	1000	2.000	1330.557	0.0074	0.555	0	12.2251	No Shear reinf. Required

Design Director
Niraj Patel JV



Proof Checked

Prof. K. K. Pathak
Department of Civil Engineering
Indian Institute of Technology
Banaras Hindu University
Varanasi-221005

MANAGER (P) TIRPCL
GANDHIDHAM



इंडियन पोर्ट रेल कारपोरेशन लिमिटेड
(भारत सरकार का उपक्रम)
Indian Port Rail Corporation Ltd.
(A Government of India Enterprise)
CIN No: U60300DL2015GOI282703



Construction of Interchange cum Road Over Bridge (ROB) at LC 236 (Kutch Salt - Junction) on NH 141 (Phase- I) in the State of Gujarat under EPC mode.

EPC Contractor:

Niraj - Patel JV

BB2 S 60, "NEELKANTH", ZANDA CHOWK,
GANDHIDHAM, KUTCH, GUJARAT - 370201.



Design of ROB Test Pile @ Ch.0+639

Sep 2020

Design Consultants:



Nivedita Consultants

B-98, Sector - A, Sanik Vihar Colony, Nandanagar, Kunraghat, Gorakhpur -
273008 (UP) Phone: +91-0124-4054562; email: nivcons@gmail.com

AUTHORITY:

इंडियन पोर्ट रेल कॉर्पोरेशन लिमिटेड
(भारत सरकार की उद्यमिता)
Indian Port Rail Corporation Ltd.
(A Government of India Enterprise)
CIN No. U90300DL30150G0242703

**PROJECT: Construction of Interchange cum ROB**

Construction of Interchange cum Road Over Bridge (ROB) at LC 236 (Kutch salt junctio) on NH 141 (Phase-1) in the state of Gujrath under EPC mode.

EPC CONTRACTOR:

M/S NIRAJ-PATEL JV

BBZ S 60, "Neelkanth" Zanda chowl, Gandhidhsm, Kutch,Gujrat- 370201

THIRD PARTY PROOF CONSULTANT:

Indian Institute of Technology (IIT) Varanasi

IIT-BHU, Banaras Hindu University Campus,
Uttar Pradesh 221005

PROOF CONSULTANT:

M/s Nitya Nayra Civil Solution PVT. LTD

1/70, TF-1, MIG SEC-1, Vasundhra, Ghaziabad - 201 012, Uttar Pradesh, India

TITLE OF DOCUMENT:

Design of ROB TEST PILE at CH:0+639.1

Doc. Number:	KUT-TEST PILE-ROB-RLY-CH*0+639.1-DN-01	Prepared By:	CN
Rev. No:	R0	Checked By:	NK
Date:	8/9/2020	Approved By:	NK

Date:	Rev No.	Revision	By
8/9/2020	R0	For Review and Approval	CN

DESIGN CONSULTANT:

email: nivcons@gmail.com



Nivedita Consulting

B - 98, Sector - A, Sanik Vihar Colony, Nandanagar, Kunraghat,
Gorakhpur - 273008 (UP) Phone: +91-0124-4054562;

Project:	Construction of Interchange cum ROB	Nirvita Consultants
Doc. Title	Design of ROB TEST PILE at CH:0+639.1	
Doc. no.	KUT-TEST PILE-ROB-RLY-CH"0+639.1-DN-01	Rev R0

DESIGN OF TEST PILE :

Vertical Test Load

Vertical Load Capacity for test pile	=	400 T
Test Load for test Pile	=	400×2.5
	=	<u>1000 Ton</u>

Calculation of lateral load.

*Non-seismic & submerged condition is considered

*Calculating depth of fixity

Dia of pile	=	1200 mm
Grade of concrete	fck = M	35 Mpa
E	=	320000 kg/cm ²
I	=	1E+07 cm ⁴

Stiffness factor for P.C. Cohesive soil	R	=	$\sqrt[4]{(EI/K B)}$
		=	460.00 cm

Niraj Patel
Design Director
Niraj Patel JV

Total Length of Pile	=	24 m
Free Length of Pile, L_f	=	0.0 m
Embedded length of pile, L_e	=	24.0 m
L_f/T	=	0.000
Corresponding value of L_f/T	=	1.95
Depth of fixity, L_f	=	8.97 m
Total free length $L_f + L_e$	=	8.97 m



Design Load	Q	=	10 Tonne	*For fixed head pile
-------------	---	---	----------	----------------------

Deflection at pile head top	$y = Q \cdot (L_f + L_e)^3 / 12 EI$	=	1.85 mm
-----------------------------	-------------------------------------	---	---------

* Calculation for equivalent force for free head pile		=	
L_f/T for free head pile	=	1.6	
L_f for free head pile	=	7.36 m	
$L_f + L_e$ for free head pile	=	7.36 m	



[Signature]
MANAGER (P) / IPRCL
GANDHIDHAM

Proof Checked

[Signature]
Prof. K. K. Pathak
Department of Civil Engineering
Indian Institute of Technology
Banaras Hindu University
Varanasi-221005

Project	Construction of Interchange cum ROB	Vireddi Consultants
Doc. Title	Design of ROB TEST PILE at CH:0+639.1	
Doc. no.	KUT-TEST PILE-ROB-RLY-CH'0+639.1-DN-01	Rev R0

Equivalent load for free head pile $Q_{free} = y^3 EI / (L_1 + L_f)^3 = 4.53 \text{ Tonne}$
 Say = 5.00 Tonne

Factored design load = $5 \times 2.5 = 12.5 \text{ Tonne}$

Free Head moment $M = Q_{free} * (L_1 + L_f) = 92.0 \text{ Tm}$

Moment reduction factor $m = 0.400 \text{ Tm}$

Modified design Bending Moment $M_d = 36.8 \text{ Tm}$

ULS Modified design Bending Moment $M_u = 55.2 \text{ Tm}$

R/F Calculation of test Pile

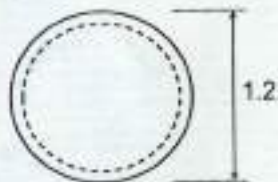

- Pile Dia D = 1200 mm
- Clear cover = 75 mm
- Dia of bar = 16 mm
- Nos. of Bars = 24 Nos
- Effective cover = 83 mm
- Reinf Circular dia = 1034 mm
- Spacing = 135.4 mm
- Area of steel provided = 4825 mm²



Material Properties:

- f_{ck} = 35 N/mm²
- f_{yk} = 550 N/mm²
- E_s = 200000 N/mm²

- % steel provided = 0.43 %
- Minimum % steel = 0.4 % OK

xu/D	Pu	Mu
	T	Tm
1E-27	-229.8	0.7
0.2	65.2	136.0
0.4	457.8	239.6
0.6	892.8	256.4
0.8	1305.0	198.3
1	1624.3	106.1
1.2	1775.7	56.4
1.4	1854.9	29.0
1.6	1899.8	11.8
1.8	1925.2	1.1
2	1938.4	-5.0

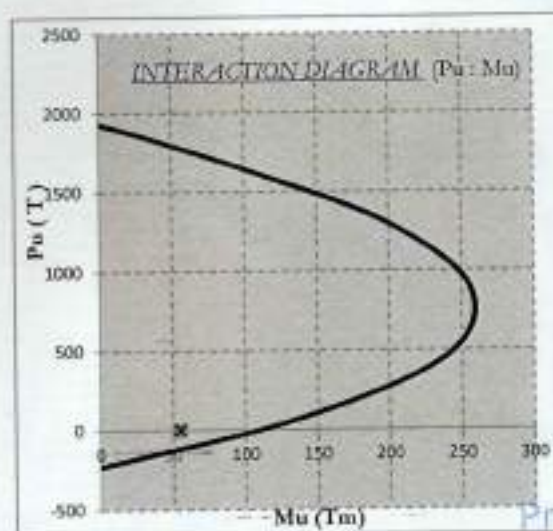

MANAGER (P) / IPREL
GANDHIDHAM

Pu = 0 T
 Mu = 55.2 Tm

Mu capacity = 106 Tm > 55.2 Tonne OK

Proof Checked
 Prof. K. K. Pathak
 Department of Civ
 Indian Institute of
 Banaras Hindu U
 Varanasi-221005

Annexure -V

भारत सरकार
सड़क परिवहन एव राजमार्ग मन्त्रालय

कार्यालय, क्षेत्रिय अधिकारी,
न्यू सचिवालय, ब्लॉक नं०-14
चतुर्थ तल, गाँधीनगर-382010
गुजरात
फोन/फैक्स-079-23220705



सत्यमेव जयते

GOVERNMENT OF INDIA
Ministry of Road Transport & Highways

Office of the Regional Officer
New Sachivalaya, Block No.14,
4th floor, Gandhinagar 382010
Gujarat.
Phone/Fax No. 079-23220705

Dated : October 14, 2020

RW/GNR/NH/HA/NOC/03/782

To,

The Under Secretary
Roads & Building Department
Sachivalaya
Gandhinagar, Gujarat

SUB: Construction of Interchange cum Road Over Bridge (ROB) at km 367.924, LC 236 (Kutchh Salt Junction) on NH-141 in the State of Gujarat – Approval of Revised Temporary Traffic Diversion Plan Reg.

Sir,

Please refer to your letter no. RLY-13-2016-2631-M dated 16/09/2020, submitting therewith the revised proposal for Temporary Traffic Diversion for the work cited under subject above, to this office for approval.

2. The proposal has been examined and the same is found to be in order. Accordingly, in supersession of this office letter no. RW/GNR/Works/529/GJ/2017/393 dated 08/12/2017, the Revised Temporary Traffic /Diversion Plan for Construction of Interchange cum Road Over Bridge (ROB) at km 367.924, LC 236 (Kutchh Salt Junction) on NH-141 in the State of Gujarat, is hereby granted by the Competent Authority, subject to the following conditions.

2.1 M/s IPRCL will follow the provisions for the approved revised traffic diversion plan as per IRC SP:55.

2.2 During construction and operation of the diversion road, traffic safety provisions as per IRC SP:88 shall be strictly followed, under the supervision of concerned Executive Engineer, National Highway Division, Gujarat.

2.3 There shall be no restriction on NH ROW by M/s IPRCL and future development of the National Highway.

2.4 There shall be sufficient provision for drainage arrangement made by M/s IPRCL on the diversion road and restored existing National Highway, so that no water stagnation occurs.

2.5 The diversion road shall be constructed and maintained operational by M/s IPRCL under the direct supervision of concerned Executive Engineer, National Highway Division, Gujarat. Further restoration of existing NH road shall be done under the direct supervision of concerned Executive Engineer, National Highway Division, Gujarat. Failure to adhere stipulation will warrant action against M/s IPRCL by concerned Executive Engineer, National Highway Division, Gujarat under Section 36 of The Control of National Highway (Land and Traffic) Act, 2002.

Over
H
Harsh Prabhakar
Executive Engineer
Office, Gandhinagar
Ministry of Road Transport & Highways
Government of India

URGENT/ BY EMAIL

2.6 Any deviation to the instant approval shall be approved by MoRTH prior to execution at site.

2.7 All order related to Temporary closure of traffic on Highway for construction of instant ROB along with diversion of traffic on diversion road shall be issued by the concerned Executive Engineer, National Highway Division, Gujarat under Section 30 and Section 33 of The Control of National Highway (Land and Traffic) Act, 2002.

2.8 Three copies of 'as laid drawings' of work (hard and soft copies) with geotagged photographs and geo-tagged video recordings of work executed (with respect to the NH) and after complete restoration shall be submitted to the Authority for verification.

2.9 Properly designed direction sign boards as per IRC guidelines should be fixed at appropriate locations for safety of road users.

2.10 24x7 deployment of trained manpower for traffic regulation at desired locations to avoid the conflict of traffic and for ensuring smooth flow of traffic as per approved diversion plan, should be ensured by M/s IPRCL.

2.11 A detailed pamphlet should be prepared in Hindi/ Gujarati language indicating origin and destination along with route as per approved diversion plan. The same should be circulated during the execution of project to all road users for proper traffic management.

Encl: Approved Revised Temporary Traffic Diversion Plan.

Yours Sincerely,

HARSH PRABHAKAR
EXECUTIVE ENGINEER
FOR HIGHWAY ADMINISTRATION

Copy To:

1. The Executive Engineer, National Highway Division, Gandhidham., for information and necessary action.
2. The Addl. General Manager (P), Ahmedabad, Indian Port Rail & Ropeway Corporation Ltd., Nirman Bhawan, Mumbai Port Trust Building, Mazgaon, Mumbai., for information and necessary action.

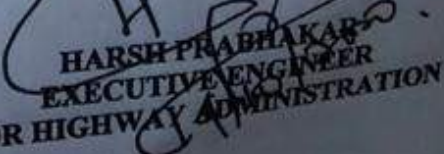
HARSH PRABHAKAR
EXECUTIVE ENGINEER
FOR HIGHWAY ADMINISTRATION

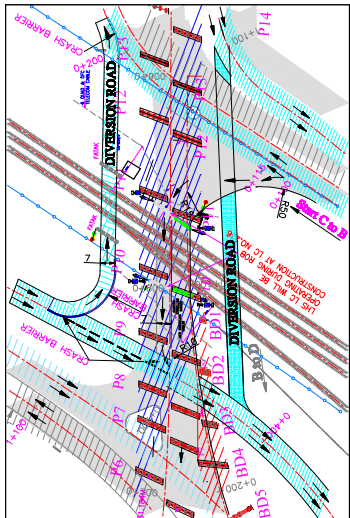
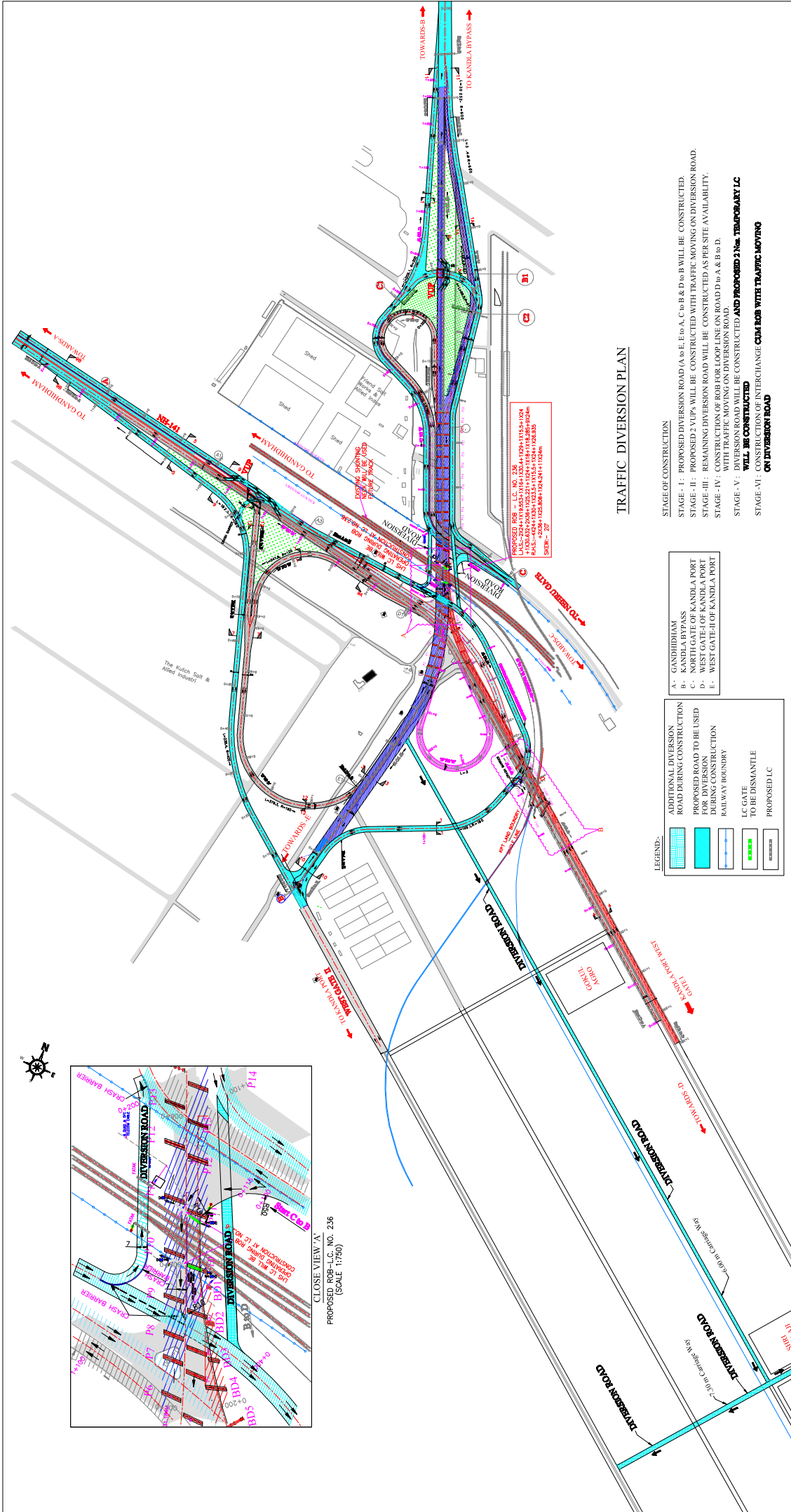

CLOSE VIEW 'A'
PROPOSED ROB-L.C. NO. 236
(SCALE 1:750)

TRAFFIC DIVERSION PLAN

- STAGE OF CONSTRUCTION**
- STAGE - I: PROPOSED DIVERSION ROAD (A to E, E to A, C to B & D to B) WILL BE CONSTRUCTED.
 - STAGE - II: REMAINING 2 V.L.P.S WILL BE CONSTRUCTED WITH TRAFFIC MOVING ON DIVERSION ROAD.
 - STAGE - III: REMAINING DIVERSION ROAD WILL BE CONSTRUCTED AS PER SITE AVAILABILITY.
 - STAGE - IV: CONSTRUCTION OF ROB FOR LOOP LINE ON ROAD D to A & B to D WITH TRAFFIC MOVING ON DIVERSION ROAD.
 - STAGE - V: EXISTING ROAD WILL BE CONSTRUCTED **AND PROPOSED 2 Nos. TEMPORARY LC WILL BE CONSTRUCTED**.
 - STAGE - VI: CONSTRUCTION OF INTERCHANGE: **CUM ROB WITH TRAFFIC MOVING ON DIVERSION ROAD**

LEGEND:

	ADDITIONAL DIVERSION ROAD DURING CONSTRUCTION
	PROPOSED ROAD TO BE USED FOR DIVERSION
	RAILWAY CONSTRUCTION
	RAILWAY BOUNDARY
	LC GATE TO BE DISMANTLE
	PROPOSED LC

- ADDITIONAL DIVERSION ROAD DURING CONSTRUCTION**
- A - GANDHIDHAM
 - B - KANDLA BYPASS
 - C - NORTH GATE OF KANDLA PORT
 - D - SOUTH GATE OF KANDLA PORT
 - E - WEST GATE OF KANDLA PORT

CLIENT:-		INDIAN PORT RAIL & ROPEWAY CORPORATION LTD. (IPRCL) BUILDING: M. P. NIRMAN BHAVAN, CORPORATE OFFICE: 4TH, MUMBAI PORT TRUST, MAZGAON, EAST, MAHARASHTRA, 400010	EPC CONTRACTOR:-		M/s. NIRAJ-PATEL JV B-2 S. 60, "NEELKANTH" ZANDA CHOK, GANDHIDHAM, KUTCH, GUJARAT - 370201
DEENDAYAL PORT TRUST P.O Box-50, Administrative Office Building, Gandhidham, Kutch, Gujarat, India - 370201			PROJECT:-	TRAFFIC DIVERSION PLAN	DATE: 02/07/2020
			CONSTRUCTION OF INTERCHANGE CUM ROAD OVER BRIDGE (ROB) AT LC 236 (KUTCH SALT JUNCTION) ON NH 141 (PHASE-II) IN THE STATE OF GUJARAT UNDER EPC MODE.	SCALE:	REV:
				SIZE:	RO
				DRG. NO: NP/IV/ROB/KANDLA/TD/008	SHEET:

Annexure -VI



INDIAN PORT RAIL & ROPEWAY CORPORATION LTD. (IPRCL)



BUILDING, M. P, NIRMAN BHAVAN, CORPORATE
OFFICE: 4TH, MUMBAI PORT TRUST, MAZGAON,
EAST, MAHARASHTRA 400010

**CONSTRUCTION OF INTERCHANGE CUM ROAD OVER
BRIDGE (ROB) AT LC 236 (KUTCH SALT JUNCTION) ON
NH 141 (PHASE-I) IN THE STATE OF GUJARAT UNDER
EPC MODE.**

DRAWINGS PIPE CULVERT

DESIGN CONSULTANT:-



M/S. NIVEDITA CONSULTANTS
ARCHITECTURAL, CIVIL AND STRUCTURAL
ENGINEERING CONSULTANTS

PROOF CONSULTANT:-



M/S NITYA NARYRA CIVIL
SOLUTIONS PVT. LTD.
BHOPAL

CLIENT :-



INDIAN PORT RAIL & ROPEWAY
CORPORATION LTD. (IPRCL)
BUILDING, M. P, NIRMAN BHAVAN, CORPORATE
OFFICE: 4TH, MUMBAI PORT TRUST,
MAZGAON, EAST, MAHARASHTRA 400010

EMPLOYER :-



DEENDAYAL PORT TRUST
P.O. BOX NO - 50, ADMIN OFFICE BUILDING,
TACORE ROAD, GANDHIDHAM (KUTCH)
GUJARAT-370201

EPC CONTRACTOR:-

SAFETY CONSULTANT:-



M/S. NIRAJ-PATEL JV
B82 S 60, "NEELKANTH" ZANDA CHOWK,
GANDHIDHAM, KUTCH, GUJARAT - 370201
M/S FORGIVING ROADS LLP
GURUGRAM

THIRD PARTY PROOF CONSULTANT:



Indian Institute of Technology
(IIT) Varanasi
IIT-BHU, Banaras Hindu University Campus,
Uttar Pradesh 221005

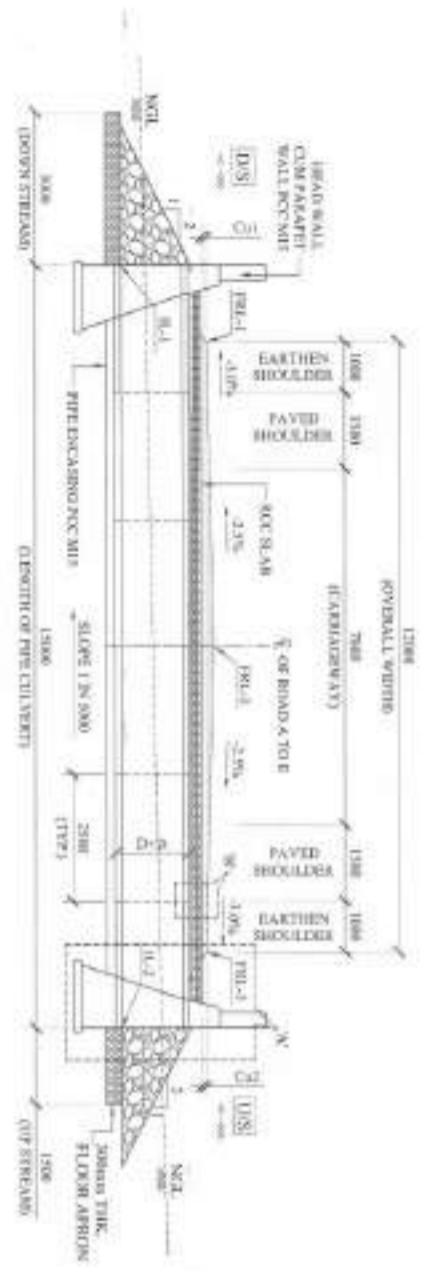

SECTION 1-1
SCALE 1:100

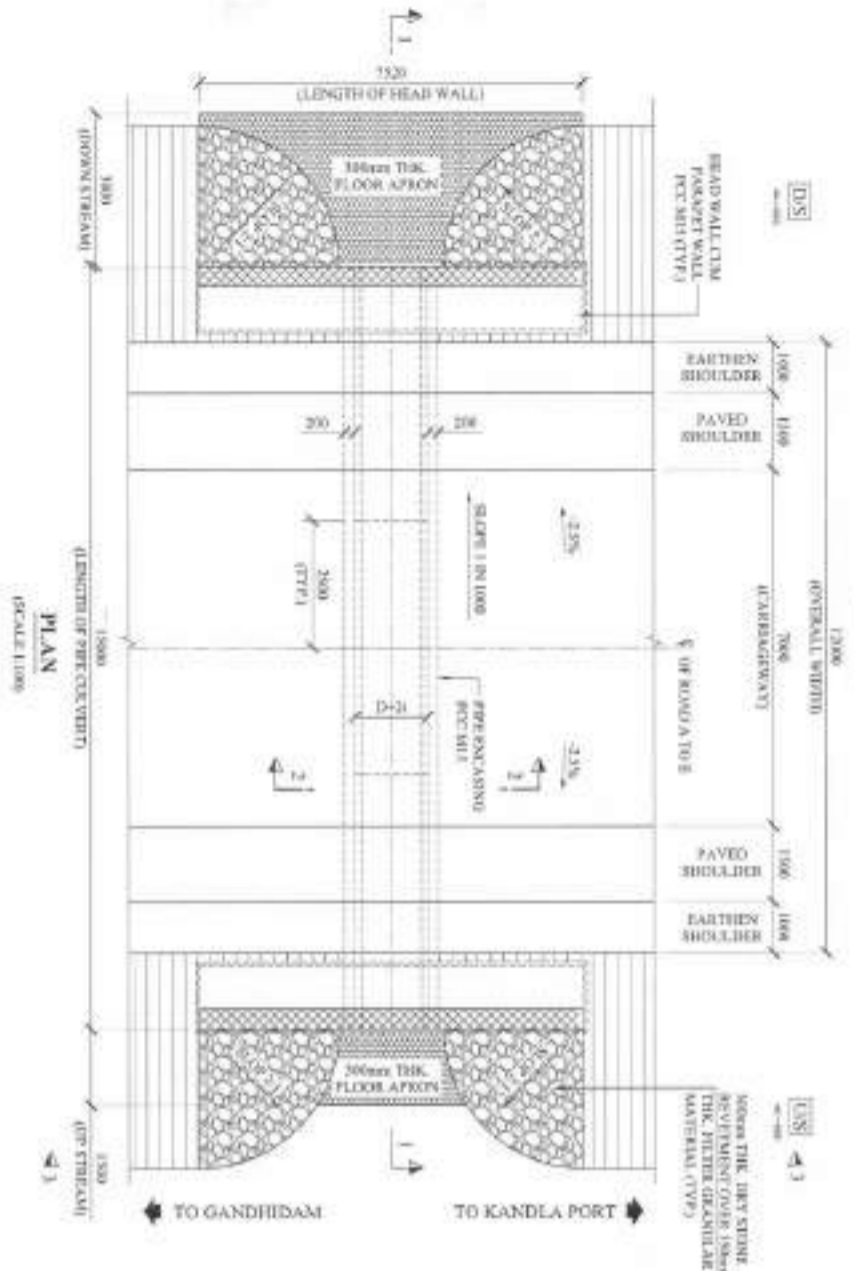

PLAN
SCALE 1:100

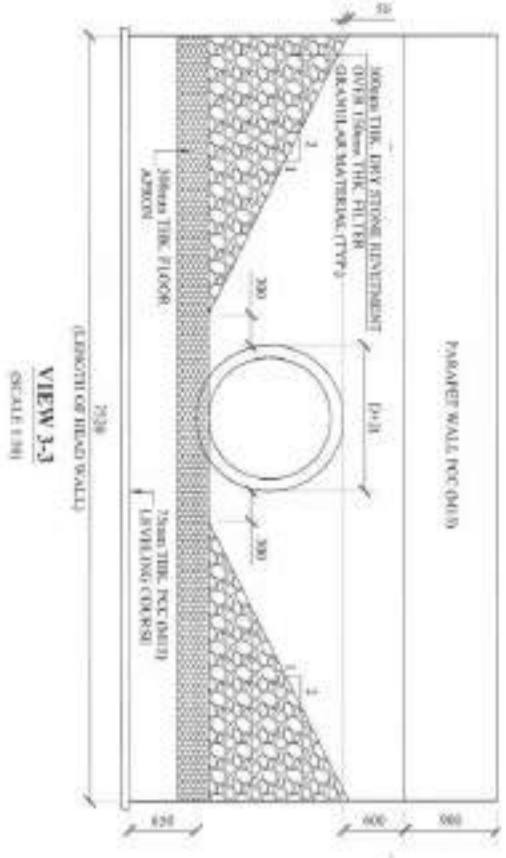

VIEW 3-3
SCALE 1:50

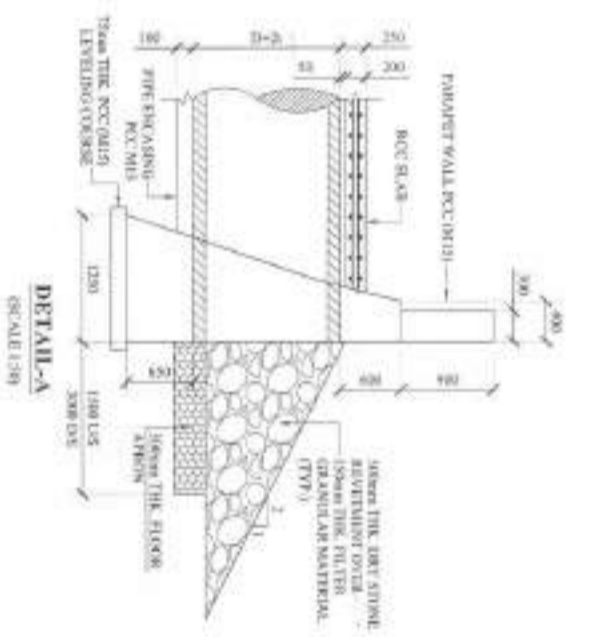

DETAIL-A
SCALE 1:50

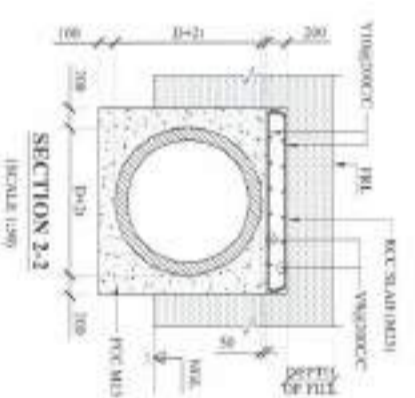

SECTION 2-2
SCALE 1:50

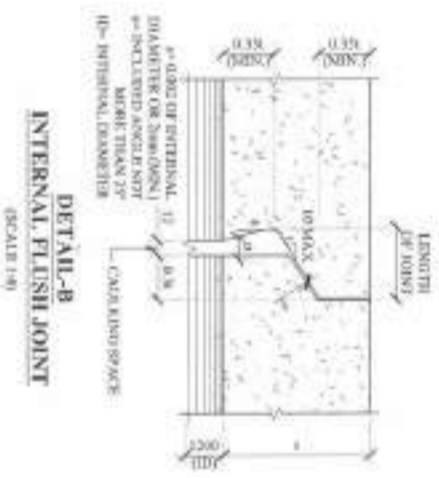

DETAIL-B
INTERNAL FLASH JOINT
SCALE 1:40

SCHEDULE OF PIPE CULVERT

SR	DISIGN	NO. OF	EX. OF	TH. OF	EST. 1	EST. 2	EST. 3	EST. 4	EST. 5	EST. 6	EST. 7	EST. 8	EST. 9	EST. 10
01	500 CHAINAGE	PPFS	1	1.200	0.120	9.160	9.320	4.160	7.970	2.264	7.299	0.189	6.888	

Jt. GENERAL MANAGER, (P)
IPRCL/GANDHIDHAM

[Signature]

Deputy Director
Niraj Patel JV

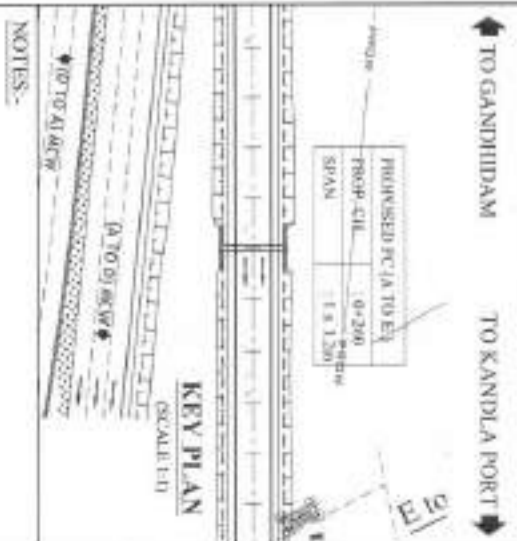

NOTES-

1. ALL DIMENSIONS ARE IN mm UNLESS OTHERWISE MENTIONED.
2. THIS DRAWING SHOULD NOT BE SCALED, ONLY WRITTEN DIMENSION TO BE FOLLOWED.
3. LONGITUDINAL SLOPE OF PIPE SHOULD BE MINIMUM OF 1 IN 1000.
4. PITCHING AND REVEALMENT SHALL BE DONE AS PER SEC SP-15.
5. ALL RCC PILES TO BE OF GRADE 100% CONFORMING TO IS 498.
6. 150mm FILTER MEDIA SHALL BE PLACED BENEATH STONE PITCHING.
7. CULVERT HEADWALLS ARE AS PER SP-13 OF IRC.
8. THE BERRING BELOW THE PIPE AND HOODRADIATION FOR HEADWALL SHALL BE PLACED OVER A FIRM STRATA.
9. IN BACKFILL BELOW PROPOSED 500mm THICK BOLLER FILLING BELOW PIPE BERRING AND BELOW HEADWALL BOLLER FILLING CONSIST OF QUARRY DUST (60% DOWN IS SEVEN) AND ROAD DUST WITH 95% COMPACTION.
10. PIPE LAYING AND PIPE SHALL BE JOINED BY INTERNAL FLASH JOINT AS PER IS 458 & MORTAR SPECIFICATIONS: IS 2586.
11. THE LENGTH OF PIPE IS MENTIONED 2500 (TYPE) BUT IN CASE IF LENGTH REQUIRED IS LESS THAN 2500 THEN LENGTH OF CULVERT ADJUSTED ACCORDINGLY.
12. THIS DRAWING SHALL BE READ IN CONJUNCTION WITH RELEVANT HIGHWAY DRAWINGS: P&L & C&M&S, SUPER ELEVATION AT PARTICULAR LOCATION SHALL BE VERIFIED WITH THE HIGHWAY DRAWING.
13. ENCASED ROAD CRUST AS PER IRC SP-48:2014.
14. AFTER INSTALLATION OF PILES THE GAPS IN BETWEEN THE PILES SHALL BE FILLED WITH CEMENT SAND MORTAR.
15. DISCREPANCY IF ANY IS TO BE IMMEDIATELY BROUGHT ON TO THE NOTICE OF ENGINEER FOR NECESSARY MODIFICATION IN THE DRAWING.
16. SEISMIC ZONE - V.
17. AT THE ENDS OF CULVERT ADEQUATE GUTTER WALL SHOULD BE PROVIDED IN FOLLOWING CASES:
 - A) WHERE INVERT LEVEL IS HIGHER THAN GROUND LEVEL AT ENDS OF CULVERTS.
 - B) WHERE UNSUITABLE SOIL IS REPLACED BY GRANULAR MATERIAL.
18. GRADE OF STEEL SHALL BE Fe-500D CONFORMING TO IS 1786.
19. CLEAR COVER TO ENCASED SLAB SHALL BE 25mm.
20. EXACT LENGTH TO BE PROVIDED AS PER CORR. PROVISION.

FOR REVIEW & APPROVAL

DESIGNER: DEEPAVAL PARI SASTI
 CHECKER: N. S. KUMAR
 DATE: 14/08/2024
 PROJECT: GAD OF PIPE CULVERT AT CH- 0+260 (A TO E)
 SHEET: 1 OF 1
 SCALE: AS SHOWN
 PROJECT NO: LCP20-KUTCH-JUN-NH-141-ST-P-C-101

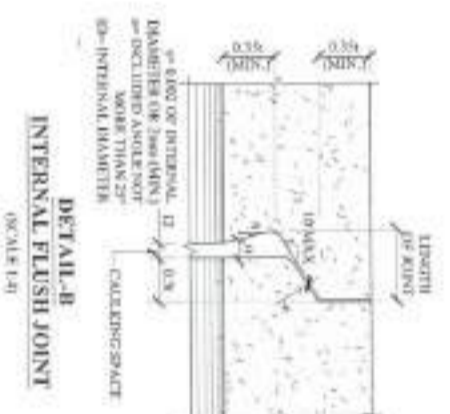
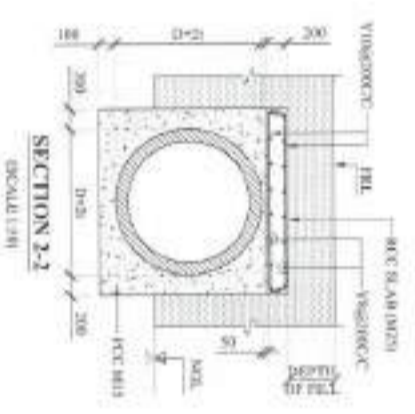
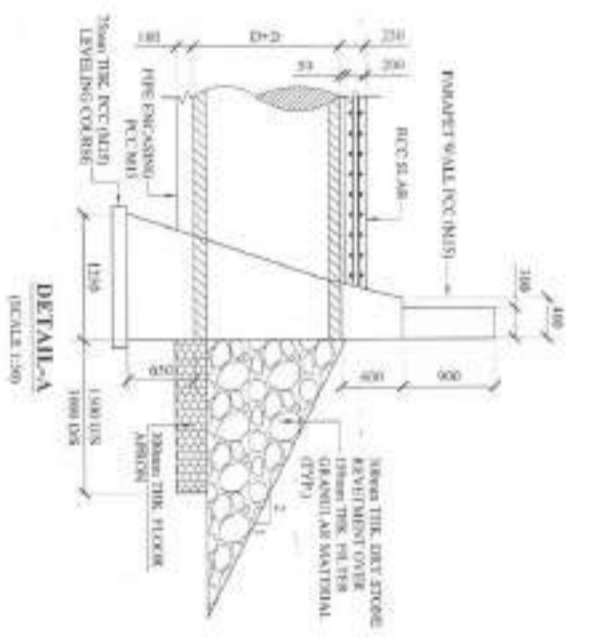
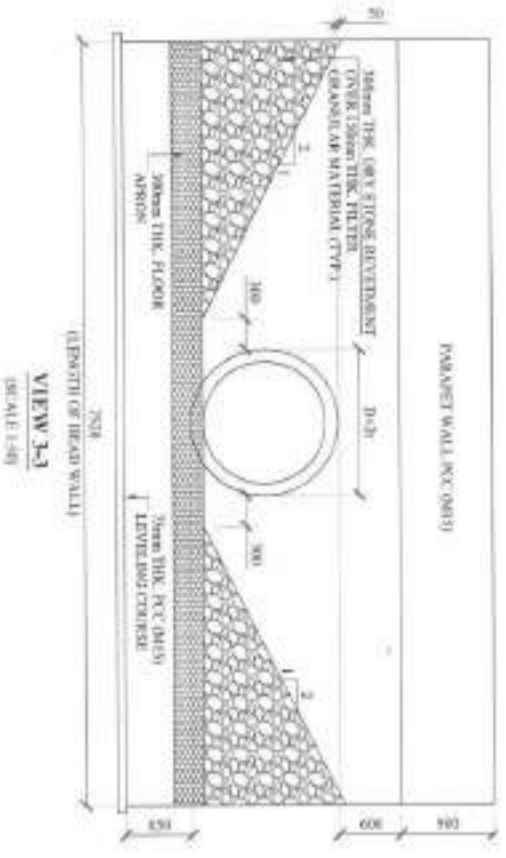
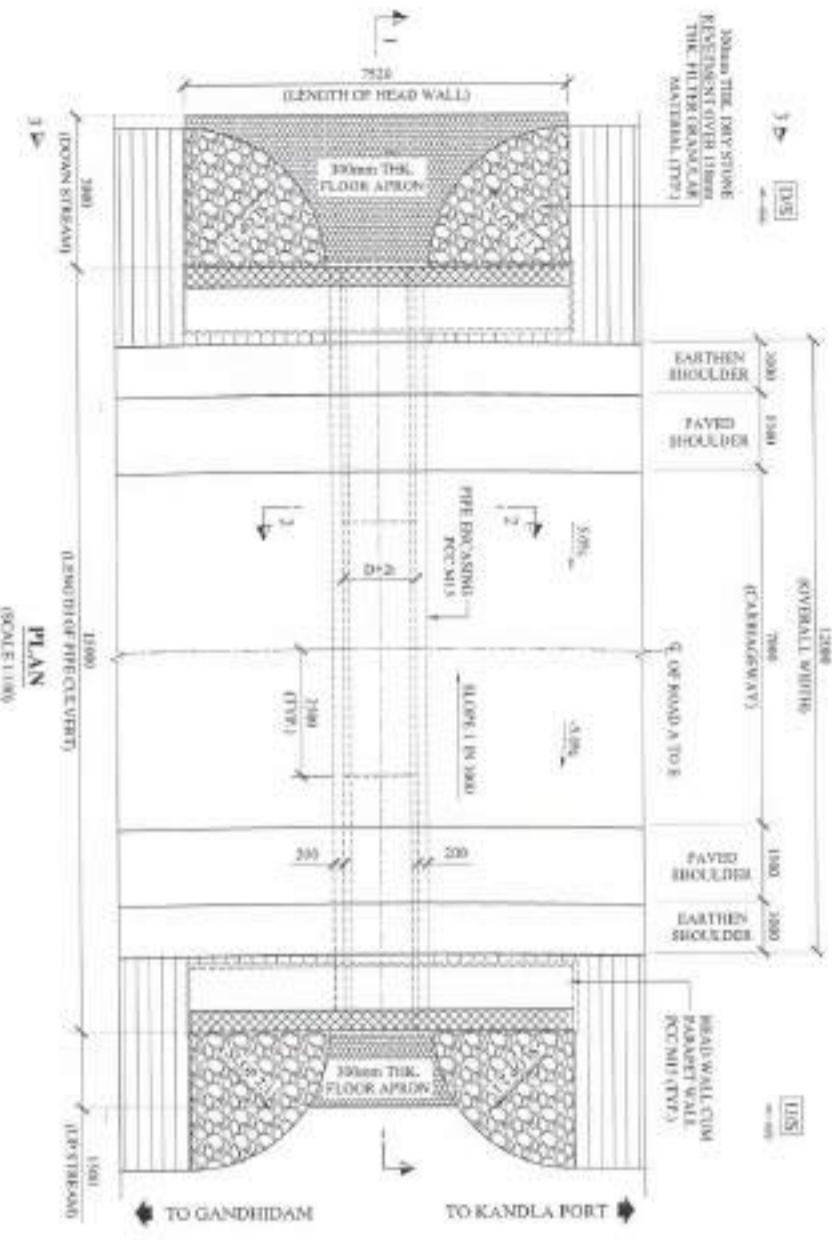
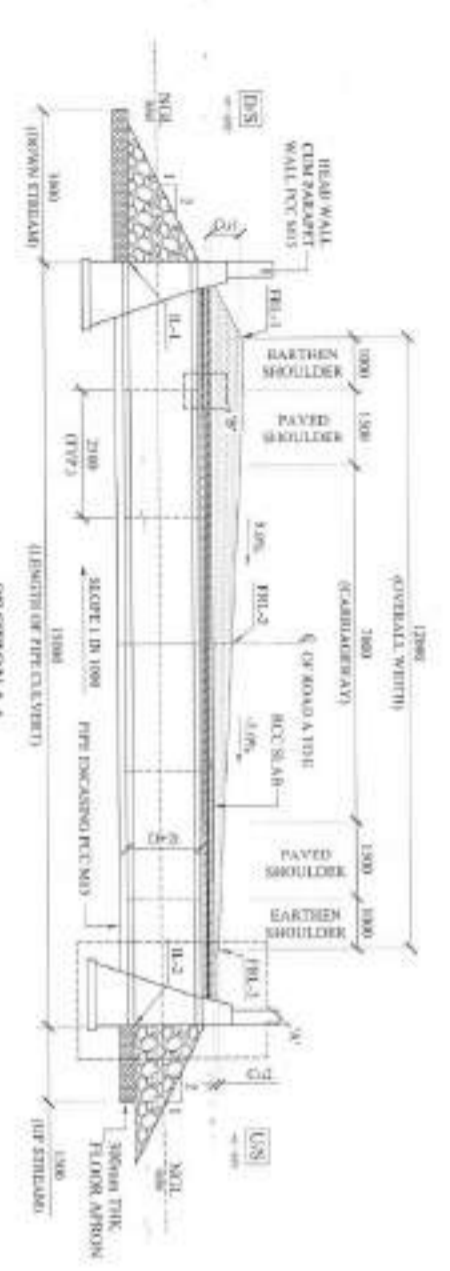

SCHEDULE OF PIPE CULVERT

Sl. No.	SECTION	NO. OF PIPES	DIAM. OF PIPE (mm)	THICK. OF PIPE (mm)	PH-1 (mm)	PH-2 (mm)	PH-3 (mm)	PH-4 (mm)	PH-5 (mm)	PH-6 (mm)	PH-7 (mm)	PH-8 (mm)	PH-9 (mm)	PH-10 (mm)	PH-11 (mm)	PH-12 (mm)	PH-13 (mm)	PH-14 (mm)	PH-15 (mm)	PH-16 (mm)	PH-17 (mm)	PH-18 (mm)	PH-19 (mm)	PH-20 (mm)	
01	0+400	1	1200	0.120	9.112	9.112	8.822	7.899	7.148	7.100	6.640	6.100													

DESIGNER: NITIN NAYRA CIVIL SOLUTIONS
PROJECT: GAD OF PIPE CULVERT AT CH-0+400 (A TO E)
DATE: 14-08-2024
SCALE: AS SHOWN
NO. OF SHEETS: 1 OF 1

CLIENT: BEAR PORT KAL & PARTNAR CORPORATION LTD. SMALL INDUSTRIES & COMMERCIAL DEVELOPMENT PROJECT, KANDLA PORT, KANDLA DISTRICT, GUJARAT.

FOR REVIEW & APPROVAL:



- NOTES:-**
- ALL DIMENSIONS ARE IN mm UNLESS OTHERWISE MENTIONED.
 - THIS DRAWING SHOULD NOT BE SCALED, ONLY WRITTEN DIMENSIONS TO BE FOLLOWED.
 - LONGITUDINAL SLOPE OF PIPE SHOULD BE MINIMUM OF 1 IN 1000.
 - PITCHING AND REVERTMENT SHALL BE DONE AS PER IRC-SP-113.
 - ALL RCC PIPES TO BE OF GRADE MP4 CONCRETE, TO IS 416.
 - 150mm FILTER MEDIA SHALL BE PLACED BENEATH STONE PITCHING.
 - CU VERT HEADWALLS ARE AS PER SP-113 OF IRC.
 - THE BEDDING BELOW THE PIPE AND HEADWALLS FOR HEADWALL SHALL BE PLACED OVER A FIRM STRATA.
 - IN DISSECTION REGION PROPOSED 300mm THICK BOLLER FILING BELOW PIPE BEDDING AND BELOW HEADWALL. BOLLER FILING CONSIST OF QUARRY DUST (DOWN DOWN IS 50%) AND BOLLERS WITH 95% COMPACTION.
 - PIPE LAYING AND PIPE SHALL BE JOINED BY INTERNAL FLUSH JOINT AS PER IS 416 & NDR 011 SPECIFICATIONS (I, 2-2000).
 - THE LENGTH OF PIPE IS MENTIONED 1500 (7.7M) BUT IN CASE IF LENGTH REQUIRED IS LESS THAN 2.99 THEN LENGTH OF CULVERT ADJUSTED ACCORDINGLY.
 - THIS DRAWING SHALL BE READ IN CONNECTION WITH RELEVANT HIGHWAY DRAWINGS PRL & CAMBER SUPER ELEVATION AT PARTICULAR LOCATION SHALL BE VERIFIED WITH THE HIGHWAY DRAWING.
 - ENCASING SHALL BE PROVIDED AS MENTIONED IN DRAWING IN CASE CUSHION OVER PIPE IS LESS THAN 100MM EXCLUDING ROAD CRUST AS PER IRC-SP-42:014.
 - AFTER INSTALLATION OF PIPES, THE GAPS IN BETWEEN THE PIPES SHALL BE FILLED WITH CHAMBER SAND MORTAR.
 - DISCREPANCY IF ANY IS TO BE IMMEDIATELY REPORTED IN TO THE NOTICE OF ENGINEER FOR NECESSARY MODIFICATION IN THE DRAWING.
 - SEISMIC ZONE - V.
 - AT THE ENDS OF CULVERT APPROPRIATE CUTOFF WALL SHOULD BE PROVIDED BY FOLLOWING CASES.
 - WHERE INVERT LEVEL IS HIGHER THAN GROUND LEVEL AT ENDS OF CULVERTS
 - WHICH UNSATURABLE SOIL IS EITHER BY GRAVEL OR MATERIAL
 - GRADE OF STEEL SHALL BE F-360 COMPRESSING TO S.F.706 CLEAR COVER TO ENCASING SLAB SHALL BE 25mm.
 - LAP LENGTH TO BE PROVIDED AS PER CRRB PROVISION.

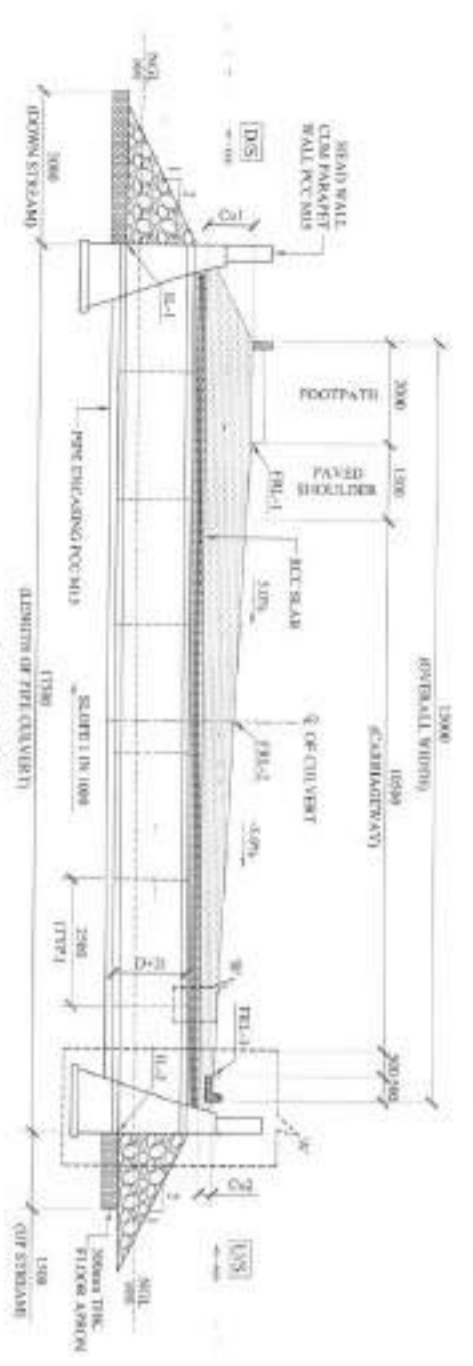

SECTION I-1
(SCALE 1:100)

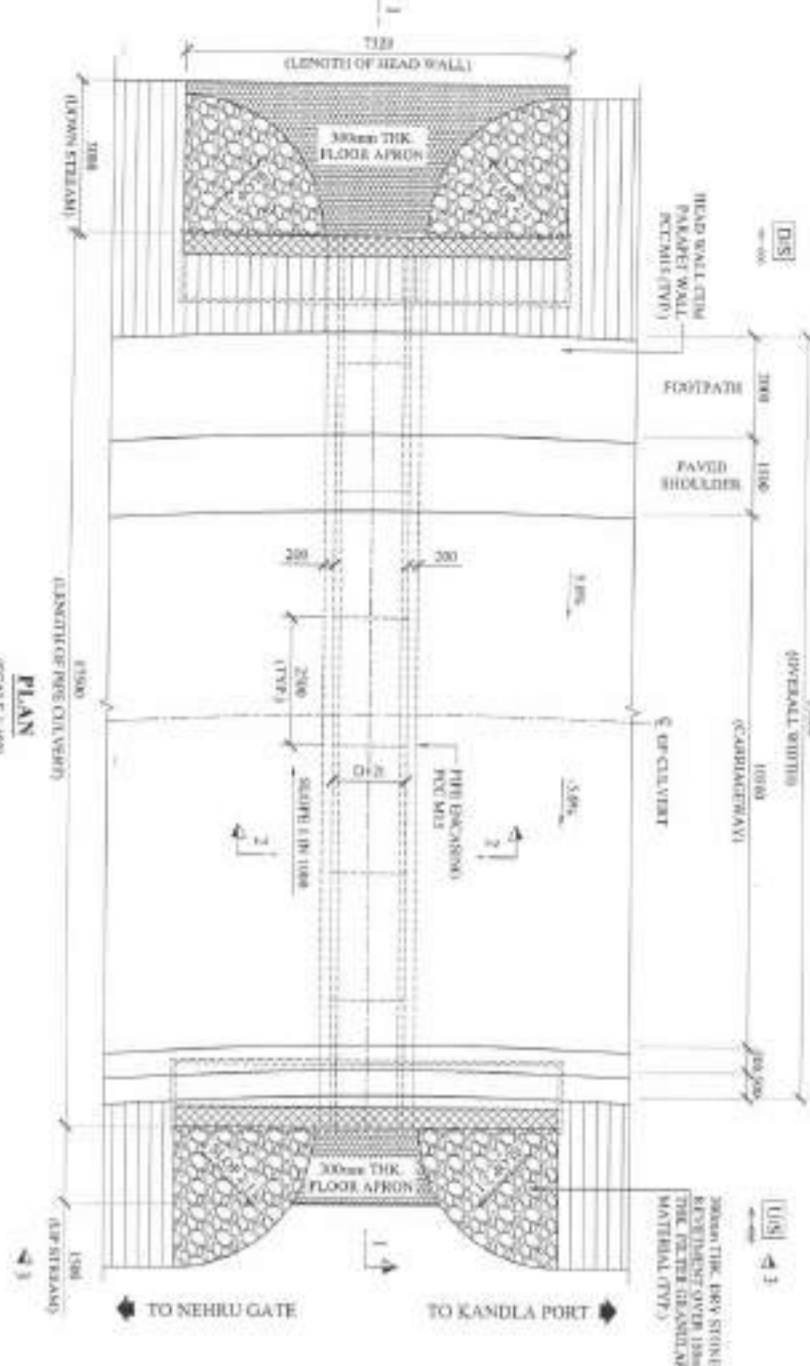

PLAN
(SCALE 1:100)

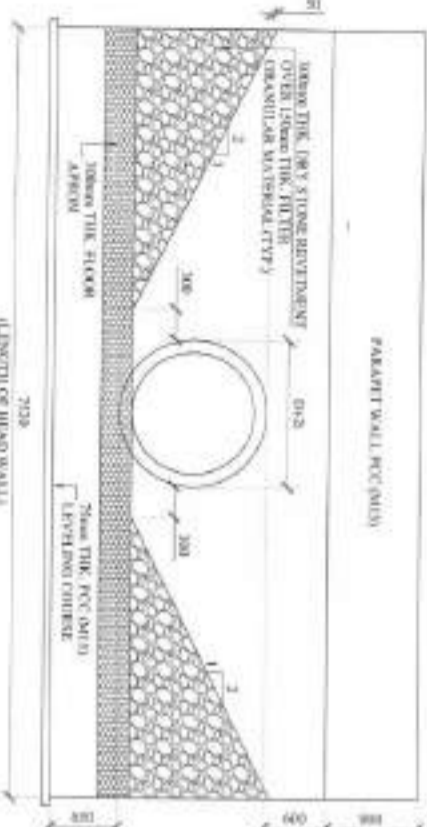

VIEW A-1
(SCALE 1:50)

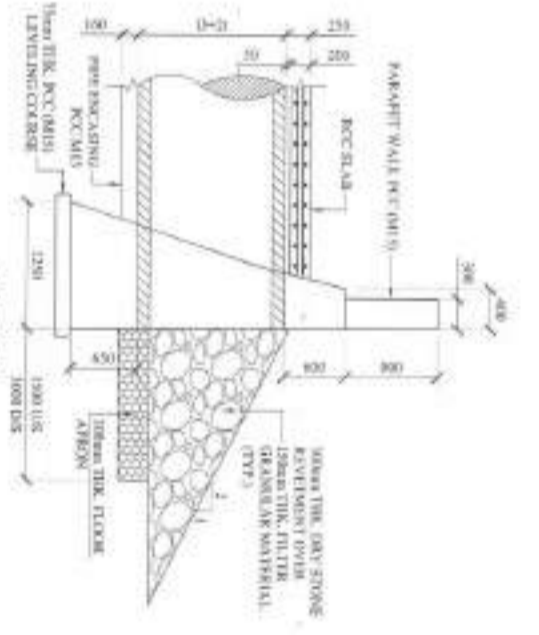

DETAIL-A
(SCALE 1:50)

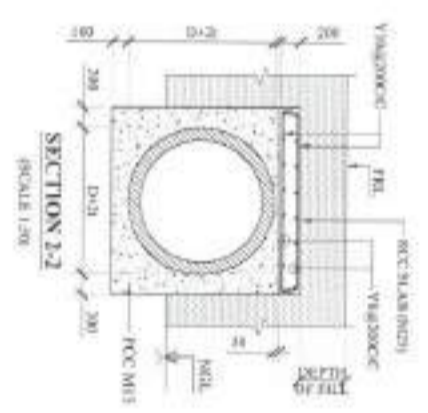

SECTION 2-2
(SCALE 1:50)

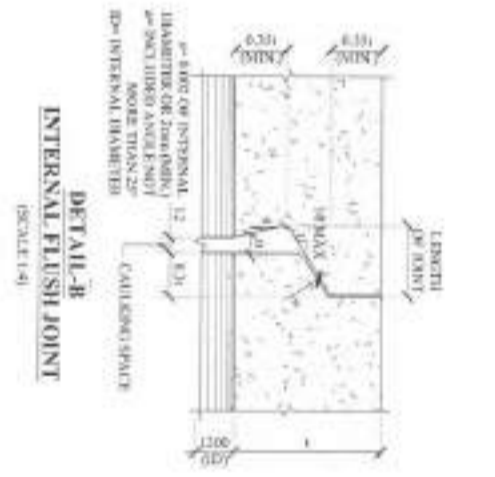

DETAIL-B
INTERNAL FLUSH JOINT
(SCALE 1:5)

SCHEDULE OF PIPE CULVERT

QTY	DESCRIPTION	UNIT	QTY	DESCRIPTION	UNIT	QTY	DESCRIPTION	UNIT	QTY	DESCRIPTION	UNIT
01	0-095/24	1	1.200	0.120	38.118	8.881	7.855	7.008	7.672	7.690	0.412
											0.238

H. GENERAL MANAGER. (P)
IPRCL/GANDHIDHAM

Design Director
Niraj Patel JV

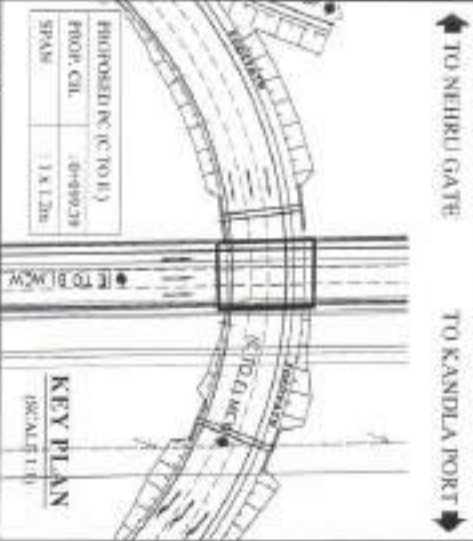

KEY PLAN
(SCALE 1:10)

- NOTES:-**
1. ALL DIMENSIONS ARE IN MM UNLESS OTHERWISE MENTIONED.
 2. THIS DRAWING SHOULD NOT BE SCALED, ONLY WRITTEN DIMENSIONS TO BE FOLLOWED.
 3. LONGITUDINAL SLOPE OF PIPE SHOULD BE MINIMUM OF 1 IN 1000.
 4. FITTING AND REVEMENT SHALL BE DONE AS PER IRC SP-13.
 5. ALL RCC PARTS TO BE OF GRADE M25 CONFORMING TO IS-456.
 6. 150mm FILTER MEDIA SHALL BE PLACED BENEATH STONE PITCHING.
 7. CULVERT HEADWALLS ARE AS PER SP-13 OF IRC.
 8. THE BEDDING BELOW THE PIPE AND FOUNDATION FOR HEADWALL SHALL BE PLACED OVER A FIRM STRATA.
 9. THE JOINTS BETWEEN HEADWALLS SHALL BE REINFORCED WITH 200mm THICK BROOKER FILLING BELOW PIPE BEDDING AND BELOW HEADWALL. BUILDER FILLING CONSIST OF QUARRY DUST (FORM DOWN IS SIZED) AND BOLLERS WITH 95% COMPACTION.
 10. PIPE LAYERS AND PIPE SHALL BE JOINED BY INTERNAL FLUSH JOINT AS PER IS-456 & MONTH SPECIFICATIONS CL-2900.
 11. THE LENGTH OF PIPE IS MENTIONED 2000 (EVEN) BUT IN CASE OF LENGTH REQUIRED IS LESS THAN 2000 THEN LENGTH OF CULVERT AS MENTIONED ACCORDING TO.
 12. THIS DRAWING SHALL BE READ IN CONJUNCTION WITH RELEVANT HIGHWAY DRAWINGS PRL & CAMBER SURVEY REPORTS AT PARTICULAR LOCATION SHALL BE VERIFIED WITH THE HIGHWAY DRAWING.
 13. ENCLOSING SHALL BE PROVIDED AS MENTIONED IN DRAWING IN CASE CURB OVER PIPE IS LESS THAN 600MM INCLUDING ROAD CRUST AS PER IRC SP-44-2014.
 14. AFTER INSTALLATION OF PIPES, THE GAPS BETWEEN THE PIPES SHALL BE FILLED WITH COMPACT SAND MORTAR.
 15. INCONSISTENCY OF ANY IS TO BE IMMEDIATELY BROUGHT IN TO THE NOTICE OF ENGINEER FOR NECESSARY MODIFICATION IN THE DRAWING.
 16. SENSITIVE ZONE - V.
 17. AT THE ENDS OF CULVERT APPROXIMATE CUTTER WALL SHOULD BE PROVIDED IN FOLLOWING CASES.
 - A) WHERE INVERT LEVEL IS HIGHER THAN GROUND LEVEL AT ENDS OF CULVERTS.
 - B) WHERE DRAINAGE SLOPE IS REPLACED BY GRANULAR MATERIAL.
 18. GRADE OF STEEL SHALL BE F-5000 CONFORMING TO IS-1186. CLASH COVER TO ENCLOSING SLAB SHALL BE 25mm TO LAP LENGTH TO BE PROVIDED AS PER CORREL PROVISION.

FOR REVIEW & APPROVAL

APPROVALS:

DESIGNER: NITYA NAYRA CIVIL SOLUTIONS, GURUGRAM

CHECKER: NITYA NAYRA CIVIL SOLUTIONS, GURUGRAM

DATE: 14/05/2024

PROJECT: GAD OF PIPE CULVERT AT CH-0+099.39(C TO E)

SCALE: AS SHOWN

SHEET: 1 OF 1

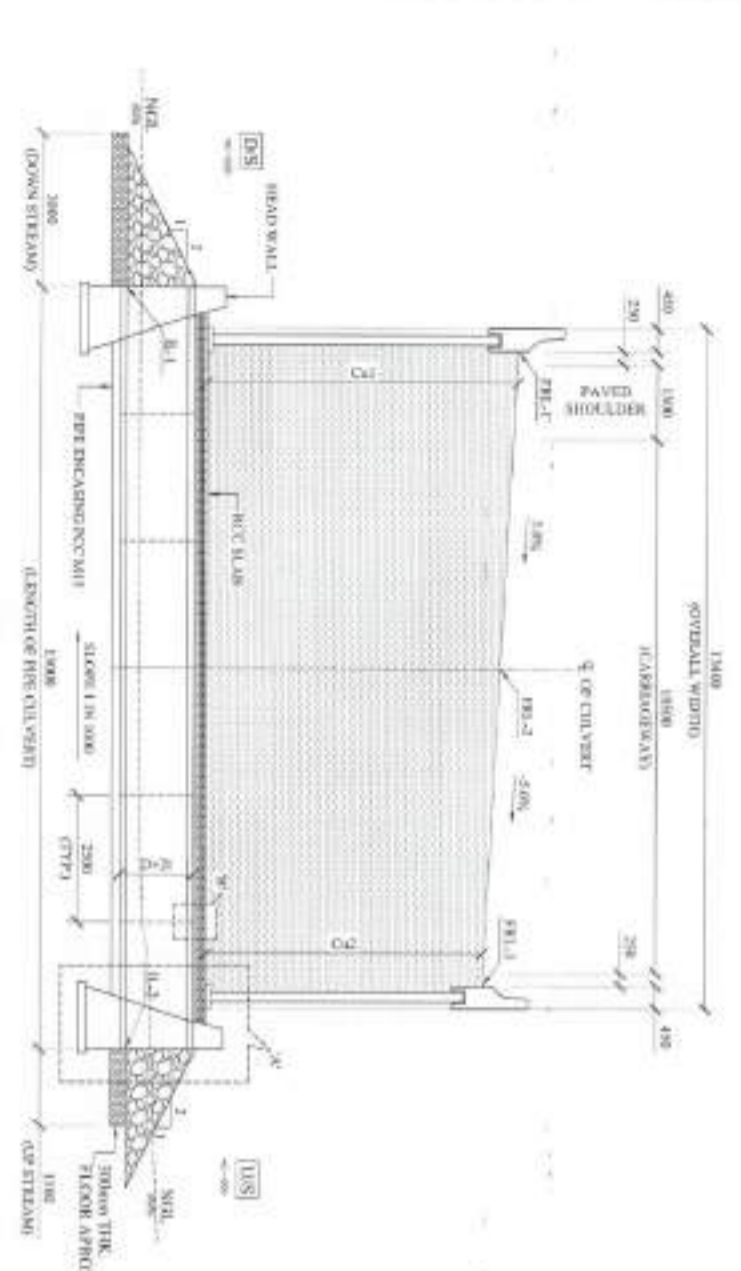

SECTION 1-1
SCALE 1:100

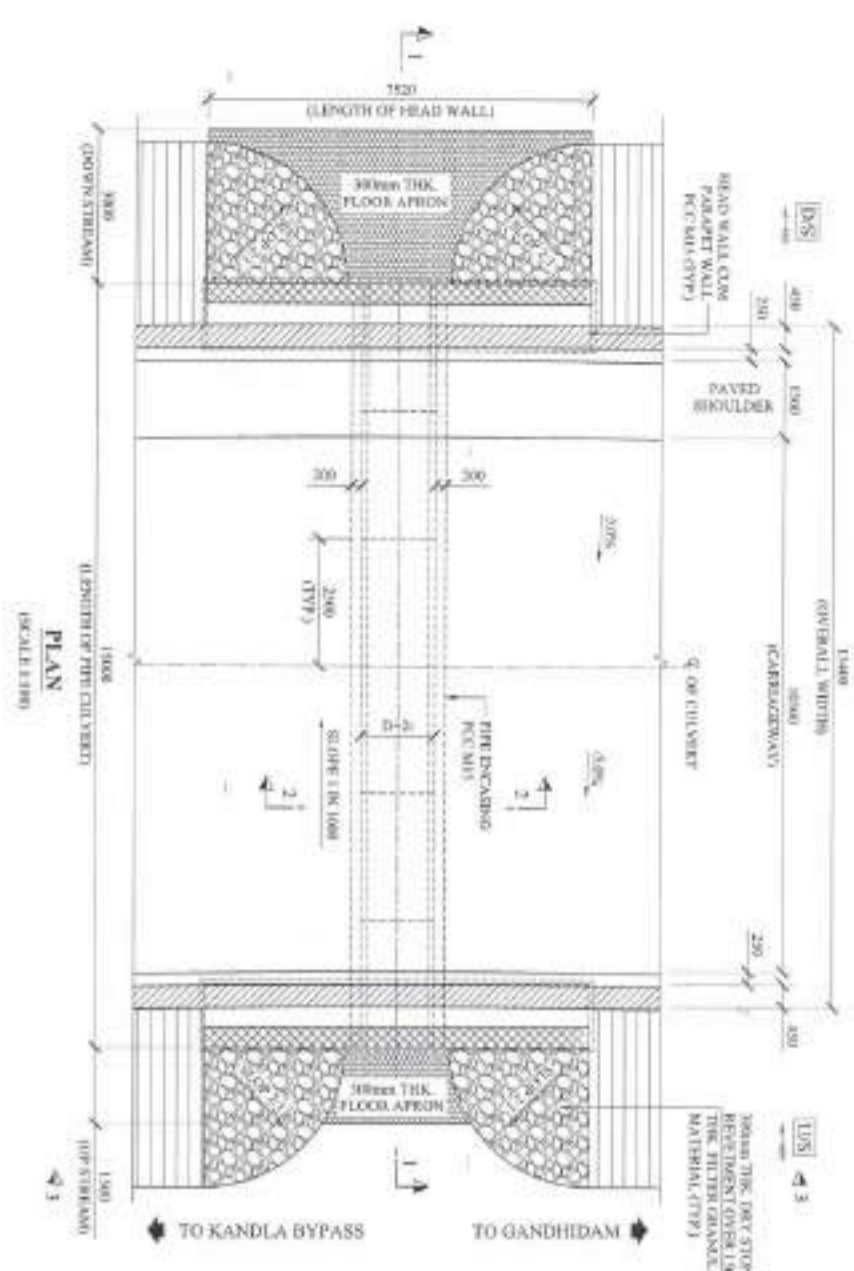

PLAN
SCALE 1:100

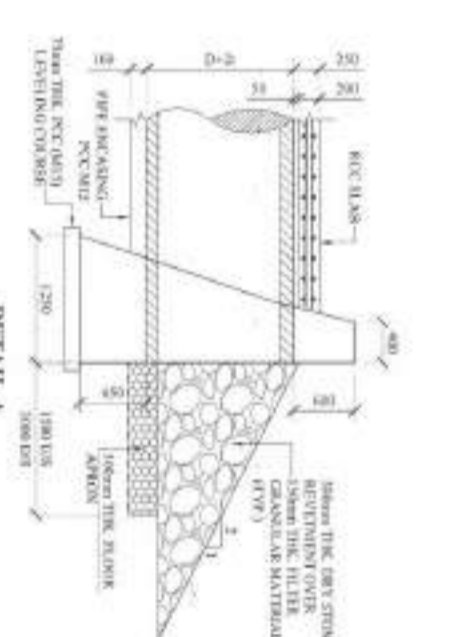

DETAIL-A
SCALE 1:50

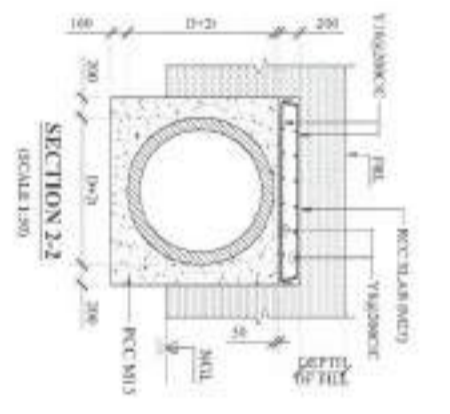

SECTION 2-2
SCALE 1:50

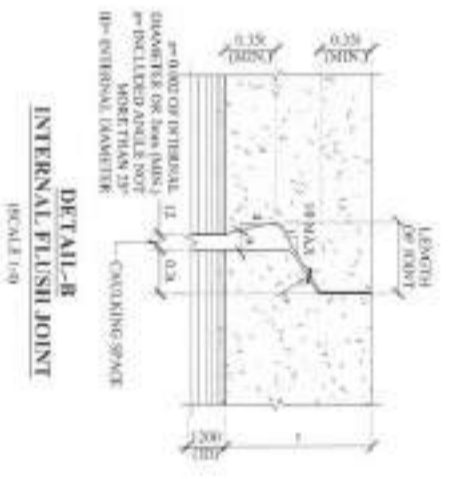

DETAIL-B
INTERNAL FLUSH JOINT
SCALE 1:50

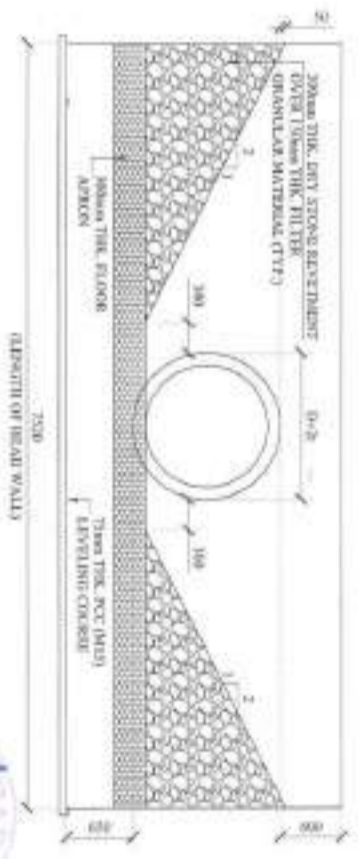

VIEW 3-3
SCALE 1:50

SCHEDULE OF PIPE CULVERT

Sl. No.	DESCRIPTION	QTY	UNIT	EST. PRICE	REMARKS
01	1-104.98	1	L200	8.120	
			R.1-1	13.021	
			R.1-2	14.708	
			R.1-3	34.136	
			R.1-4	7.179	
			R.1-5	7.298	
			DEPTH OF FILL (M)	6.870	
			AT COTTER EDGE	2.421	

FOR REVIEW & APPROVAL

DESIGNER: NITVA NAYRA CONSULTANTS
PROJECT: GAD OF PIPE CULVERT AT CH-1+049.98 (A TO D)
SCALE: 1:100
DATE: 10/01/2024
REV: 01

CLIENT: MHA
PROJECT: GAD OF PIPE CULVERT AT CH-1+049.98 (A TO D)
SCALE: 1:100
DATE: 10/01/2024
REV: 01

APPROVER: NITVA NAYRA CONSULTANTS
PROJECT: GAD OF PIPE CULVERT AT CH-1+049.98 (A TO D)
SCALE: 1:100
DATE: 10/01/2024
REV: 01

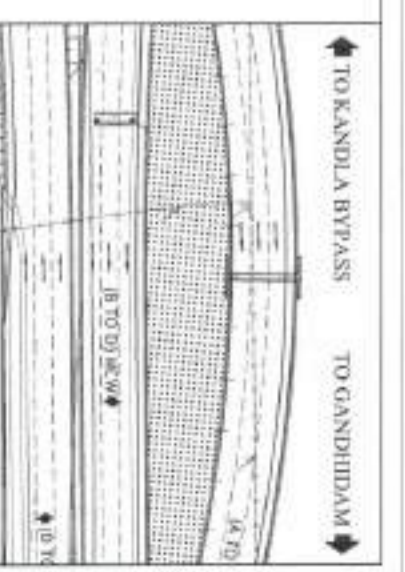

KEY PLAN
SCALE 1:10

- NOTES:-**
- ALL DIMENSIONS ARE IN MM UNLESS OTHERWISE MENTIONED.
 - THIS DRAWING SHOULD NOT BE SCALED, ONLY WRITTEN DIMENSIONS TO BE FOLLOWED.
 - CONSTRUCTION SLOPE OF PIPE SHOULD BE MINIMUM OF 1:20.
 - RETICING AND REINFORCEMENT SHALL BE DONE AS PER IS: 8013.
 - ALL RCC PILES TO BE OF GRADE SPT CONC. (GRADE TO IS: 45).
 - 150mm FILTER MEDIA SHALL BE PLACED BENEATH STONE FILLING.
 - CULVERT HEADWALLS ARE AS PER IS: 8013 OR IS: 8014.
 - THE BEDDING BELOW THE PIPE AND FOUNDATION FOR HEADWALL SHALL BE PLACED OVER A FIRM STRATA.
 - IN BLACK COTTON REGION PROVIDE 300mm THICK RIGID FILLING BELOW PIPE BEDDING AND BELOW HEADWALL, SHOULD BE FILLING CONSIST OF QUARRY DUST (PASS DOWN IS 75) AND BOLLERS WITH 5% COMPACTION.
 - PELLETS AND PILE SHALL BE JOINED BY INTERNAL FLUSH JOINT AS PER IS: 45 & IS: 8013 SPECIFICATIONS. CL: 2900.
 - THE LENGTH OF PIPE IS MENTIONED (TOP) BUT IN CASE IF LENGTH REQUIRED IS LESS THAN 2500 THEN LENGTH OF CULVERT ADJUSTED ACCORDINGLY.
 - IF DRAWING SHALL BE READ IN CONNECTION WITH RELEVANT HIGHWAY DRAWINGS P.L. & CARRIER SPEC. ELEVATIONS AT PARTICULAR LOCATION SHALL BE VERIFIED WITH THE HIGHWAY DRAWING.
 - ENCASING SHALL BE PROVIDED AS MENTIONED IN DRAWING. IN CASE CUSHION OVER PIPE IS LESS THAN 600mm EXISTING ROAD CRIST AS PER IS: 8013-8014.
 - AFTER INSTALLATION OF PIPES, THE GAPS IN BETWEEN THE PIPES SHALL BE FILLED WITH CEMENT SAND MORTAR.
 - DISCREPANCY IF ANY IS TO BE IMMEDIATELY BROUGHT IN TO THE NOTICE OF ENGINEER FOR NECESSARY MODIFICATION BY THE DRAWING.
 - SEWER ZONE - V.
 - AT THE ENDS OF CULVERT APPROPRIATE COTTER WALL SHOULD BE PROVIDED IN FOLLOWING CASES:
 - WHERE INVERT LEVEL IS HIGHER THAN CROSSLING LEVEL AT ENDS OF CULVERTS.
 - WHERE UNSATURABLE SOIL IS REPLACE BY GRANULAR MATERIAL.
 - GRADE OF STEEL SHALL BE Fe-500D (CONFORMING TO IS: 1786) CLASS COVER TO ENCASING SLAB SHALL BE 25mm.
 - LAJ LENGTH TO BE PROVIDED AS PER CORREL PROVISION.

Annexure -VII



GPCB

GUJARAT POLLUTION CONTROL BOARD

PARYAVARAN BHAVAN
Sector-10-A, Gandhinagar 382 010

Phone : (079) 23222425

(079) 23232152

Fax : (079) 23232156

Website : www.gpcb.gov.in

By R.P.A.D.

In exercise of the power conferred under section-25 of the Water (Prevention and Control of Pollution) Act-1974, under section-21 of the Air (Prevention and Control of Pollution)-1981 and Authorization under rule 6(2) of the Hazardous & Other Waste (Management & Transboundary Movement) Rules-2016, framed under the Environmental (Protection) Act-1986.

And whereas Board has received application inward No.118092 dated 23/03/2017 for the **Consolidated Consent and Authorization (CC&A)** of the Board under the provisions / rules of the aforesaid Acts. Consents & Authorization are hereby granted as under:

CONSENTS AND AUTHORISATION:

(Under the provisions /rules of the aforesaid environmental acts)

To
Mrs Patel Construction Co,
Plot No:- S.No:- 932,,
Tal:- Anjar,
Dist: Kutch-370 410.

1. Consent Order No. AWH- 85951 Date of Issue: 11/05/2017

2. The consent shall be valid up to 22/03/2022 for manufacturing of the following product:

Sr. No.	PRODUCT	QUANTITY MT/ MONTH
1.	Road Paving Material (Hot mix plant)	2500 MT/Month

3. SUBJECT TO THE FOLLOWING SPECIFIC CONDITIONS:

3.1 No ground water shall be withdrawal without obtaining prior permission from competent authority.

4. CONDITIONS UNDER WATER ACT 1974:

4.1 Industrial effluent generation from manufacturing process and other ancillary operations shall be Nil, as generated waste water shall be recycled & there shall not be waste water discharge.

4.2 The quantity of the Sewage effluent from the factory shall not exceed 0.5 KL/day.

4.3 The quality of the sewage shall conform to the following standards:

PARAMETER	PERMISSIBLE LIMIT
BOD (3 days at 27° C)	20 mg/L
Suspended Solid	30 mg/L
Residual Chlorine	Minimum 0.5 mg/L

Clean Gujarat Green Gujarat

ISO-9001-2008 & ISO-14001 - 2004 Certified Organisation

Page 1 of 6

4.4 Unit shall provide sprinkling system to mitigate dusting and also provide pacca road in premises to prevent dusting.

4.5 Sewage shall be disposed off through septic tank / soak pit system.

5. CONDITIONS UNDER AIR ACT 1981:

5.1 The following shall be used as fuel in D.G. Set.

Sr.No.	Fuel	Quantity
1.	LDO	45 ltr/hr

5.2 The flue gas emission through various stack / Vent of DG sets / Boiler / Furnace Heater shall conform the following standards

Sr. no.	Stack attached to	Stack height in Meters	APCM	Parameter	Permissible limit
1.	D. G. Set-500 KVA (stand by)	11	---	PM SO ₂ NOx	150 mg/Nm ³ 100 ppm 50 ppm

5.3 The process gas emission from the manufacturing process as well as other ancillary operations shall be as following:-

Sr. no.	Stack attached to	Stack height in meters	Air Pollution Control System	Parameter	Permissible limit
1.	Dryer	11	Dust collector & circulation scrubber	SPM SO ₂ NOx	150 mg/NM ³ 100 ppm 50 ppm

5.4 The concentration of the following parameters in the ambient air within the premises of the industry shall not exceed the limits specified hereunder as per National Ambient Air Quality Standards issued by MOEF & CC dated 16th November-2009.

Sr. No.	Pollutant	Time Weighted Average	Concentration in Ambient air in µg/M ³
1.	Sulphur Dioxide (SO ₂)	Annual 24 Hours	50 80
2.	Nitrogen Dioxide (NO ₂)	Annual 24 Hours	40 80
3.	Particulate Matter (Size less than 10 µm) OR PM ₁₀	Annual 24 Hours	60 100
4.	Particulate Matter (Size less than 2.5 µm) OR PM _{2.5}	Annual 24 Hours	40 60



GUJARAT POLLUTION CONTROL BOARD

PARYAVARAN BHAVAN
Sector-10-A, Gandhinagar 382 010
Phone : (079) 23222425
(079) 23232152
Fax : (079) 23232156
Website : www.gpcb.gov.in

5.5 The applicant shall provide portholes, ladder, platform etc at chimney(s) for monitoring the air emissions and the same shall be open for inspection. The chimney(s) vents attached to various sources of emission shall be designed by numbers such as S-1, S-2, etc. and these shall be painted / displayed to facilitate identification.

5.6 The concentration of Noise in ambient air within the premises of industrial unit shall not exceed following levels:

Between 6 A.M. to 10 P.M.: 75 dB (A)

Between 10 P.M. to 6 A.M.: 70 dB (A)

6. Authorization under Hazardous and other waste [Management, Transboundary Movement] Rules, 2016 & amended.

6.1 Authorization Number: AWH – 85951 and shall valid up to 22/03/2022.

6.2 M/s Patel Construction Co, is hereby granted an authorization to operate facility for following hazardous wastes on the premises situated at, Plot No:- S.No:- 932, Tal:- Anjar, Dist: Kutch-370 410.

Sr. No.	Waste	Quantity per Annum	Category	Mode of Disposal
1.	Used Oil	0.2 T	5.1	Collection, storage, Transportation, Disposal by selling out to registered recyclers/re-processor

6.3 The 4.authorization is granted to operate a facility for collection, storage, within factory premises, transportation, and ultimate disposal of Hazardous wastes at TSDF.

6.4 The authorization is subject to the conditions stated below and such other conditions as may be specified in the rules from time to time under the Environment (Protection) Act-1986.

6.5 GENERAL CONDITIONS OF AUTHORIZATION:

1. The authorized person shall comply with the provisions of the Environment (Protection) Act, 1986, and the rules made there under.
2. The authorization or its renewal shall be produced for inspection at the request of an officer authorized by the State Pollution Control Board.
3. The person authorized shall not rent, lend, sell, transfer or otherwise transport the hazardous and other wastes except what is permitted through this authorization.

4. Any unauthorized change in personnel, equipment or working conditions as mentioned in the application by the person authorized shall constitute a breach of his authorization.
5. Hazardous Waste generated shall be disposed off in accordance with the Hazardous Waste & other waste(Management & Transboundary Movement) Rules, 2016 as amended and unit shall have to obtain authorization of the Board for all applicable categories of Hazardous wastes.
 - (a) Used oil / spent oil shall be disposed off by selling it to registered re-refiner units only.
 - (b) Oily sludge from separators shall be dispose or of selling it to registered re-refiners unit only.
 - (c) ETP sludge shall be disposed of at TSDf approved by the Board.
 - (d) Used batteries shall be sold to the GPCB authorized dealers.
6. The person authorized shall implement Emergency Response Procedure (ERP) for which this authorization is being granted considering all site specific possible scenarios such as spillages, leakages, fire etc. and their possible impacts and also carry out mock drill in this regard at regular interval of time;
7. It is the duty of the authorized person to take prior permission of the State Pollution Control Board to close down the facility.
8. The imported hazardous and other wastes shall be fully insured for transit as well as for any accidental occurrence and its clean-up operation.
9. The record of consumption of hazardous and other wastes shall be maintained.
10. The hazardous and other waste which gets generated during recycling or reuse or recovery or pre-processing or utilization of imported hazardous or other wastes shall be treated and disposed of as per specific conditions of authorization.
11. An application for the renewal of an authorization shall be made as laid down under these Rules.
12. Any other conditions for compliance as per the Guidelines issued by the Ministry of Environment, Forest and Climate Change or Central Pollution Control Board from time to time.
13. Annual return shall be filed by June 30th for the period ensuring 31st March of the year.

7. GENERAL CONDITIONS

- 7.1 Any change in personnel, equipment or working conditions as mentioned in the consents form/order should immediately be intimated to this Board.



GUJARAT POLLUTION CONTROL BOARD

PARYAVARAN BHAVAN

Sector-10-A, Gandhinagar 382 010

Phone : (079) 23222425

(079) 23232152

Fax : (079) 23232156

Website : www.gpcb.gov.in

- 7.2 The waste generator shall be totally responsible for (i.e. Collection, storage, transportation and ultimate disposal) of the wastes generated.
- 7.3 Records of waste generation, its management and annual return shall be submitted to Gujarat Pollution Control Board in Form - 4 by 31st January of every year.
- 7.4 In case of any accident, details of the same shall be submitted in Form - 5 to Gujarat Pollution Control Board.
- 7.5 Applicant shall comply relevant provision of "Public Liability Insurance Act - 91".
- 7.6 Empty drums and containers of toxic and hazards material shall be treated as per guideline published for "management & handling of discarded containers". Records of the same shall be maintained and forwarded to Gujarat Pollution Control Board regularly.
- 7.7 In no case any kind of hazardous waste shall be imported without prior approval of appropriate authority.
- 7.8 Adequate plantation shall be carried out all along the periphery of the industrial premises in such a way that the density of plantation is at least 1000 trees per acre of land and a green belt of 10 meters width is developed.
- 7.9 The applicant shall however, not without the prior consent of the Board bring into use any new or altered outlet for the discharge of effluent or gaseous emission or sewage waste from the proposed industrial plant. The applicant is required to make applications to this Board for this purpose in the prescribed forms under the provisions of the Water Act-1974, the Air Act-1981 and the Environment (Protection) Act-1986.
- 7.10 The over all noise level in and around the plant area shall be kept well within the standards by providing noise control measures including engineering control like acoustic insulation hoods, silencers, enclosures etc on all sources of noise generation. The ambient noise level shall conform to the standards prescribed under the Environment (Protection) Act, 1986 & Rules.
- 7.11 The concentration of Noise in ambient air within the premises of industrial unit shall not exceed following levels:
 - Between 6 A.M. and 10 P.M.: 75 dB (A)
 - Between 10 P.M. and 6 A.M.: 70 dB (A)
- 7.12 In case of transport of hazardous waste to a facility for (i.e. Treatment, Storage and disposal) existing in a state other than the state where hazardous waste are generated, the occupier shall obtain "No Objection certificate" from the state pollution Control Board, the Committee of the concerned state or Union territory Administration where the facility exists.

- 7.13 Unit shall take all concrete measures to show tangible results in waste generation reduction, avoidance, reuse and recycle. Action taken in this regards shall be submitted within 03 months and also along with Form 4.
- 7.14 You shall have to display the relevant information with regard to hazardous waste as indicated in the Hon. Supreme Court's order in W.P. No.657 of 1995 dated 14th October 2003.
- 7.15 Industry shall have to display on-line data outside the main factory gate with regard to quantity and nature of hazardous chemicals being handled in the plant, including wastewater and air emissions and solid hazardous waste generated within the factory premises.

For and on behalf of
GUJARAT POLLUTION CONTROL BOARD



(Sushil Vegda)

Senior Environment Engineer

NO: PC/ CCA- KUTCH- 1273/GPCB ID: 46211/ 415000 Date: 15/6/17

ISSUED TO:

M/s Patel Construction Co,
Plot No:- S.No:- 932,,
Tal:- Anjar,
Dist: Kutch-370 410.

Annexure -VIII

11, તેના

P
G
V
C
L

.com

નું કામ
કચેરી,
હેઠળ,
માં કરવા
કામના
:-૭-૨૦

ર્થત
૩.

ભુજ

ફો
.09

બ છે.

કો

કડા

કચેરી

ચાલ

કર

વી

કે અન્ય વાહનમાં મુસાફરી કરતા પ્રવાસીઓ માસ્ક, સેનિટાઈઝરનો ઉપયોગ ન કરતા હોવા છતાં આસાનીથી મુસાફરી કરે છે. કચ્છમાં ફરી કોરોનાનો ડંખ તિલાંજલિ બન્યો છે, ત્યારે જો તકેદારી નહીં રાખવામાં આવે તો સ્થિતિ બેકાબૂ બનતા વાર નહીં લાગે.

કે, લોકડાઉન-૪થી એસટી વિભાગ દ્વારા પ્રાયોગીક ધોરણે ડેપો ટુ ડેપોના રૂટ શરૂ કરવામાં આવ્યા હતા અને હવે જિલ્લામાં ૧૭ પીકઅપ સ્ટેન્ડ પણ બનાવામાં આવ્યા છે. જ્યાં પ્રવાસીઓ બસમાં ચડી શકે છે. તો હવે કચ્છમાં જનજીવન સામાન્ય બની રહ્યું છે. ત્યારે કચ્છમાં એસટીની સેવા રાખેતા મુજબ શરૂ કરવાની

શહે
ધો

માંગ ઉઠી
પણ ગ્રા
સેવા શરૂ
ગ્રામ્ય
જવા માટે
ન હોવા
હજુ શહે:
જેના કાર
વિસ્તારમ
આવી ત
આશ લગ
એસટી બ
શરૂ કરવા
સરકાર ક
તે અંગે
આવી ન
જ સરકાર
આવશે.
આપવામ
મીટ મંડા

દીનદયાલ પોર્ટ ટ્રસ્ટ

ગુજરાત સરકારના સ્ટેટ લેવલ એનવાયરમેન્ટ ઇમ્પેક્ટ એસેસમેન્ટ ઓથોરીટી દ્વારા દીનદયાલ પોર્ટ ટ્રસ્ટની પરિયોજના “કન્સ્ટ્રક્શન ઓફ ઇન્ટરચેન્જ કમ રોડ ઓવરબ્રિજ (આર.ઓ.બી.) એટ એલસી-૨૩૬ (કચ્છ સોલ્ટ જંકશન) ઓન એન.એચ. ૧૪૧ ટુ નેહરૂ ગેટ ઓફ કંડલા પોર્ટ ગાંધીધામ, કચ્છને પર્યાવરણ અને સી.આર.ઝેડની મંજૂરી આપવામાં આવેલ છે. આ મંજૂરી સંદર્ભેના પત્રોની નકલો રાજ્ય પોલ્યુશન કંટ્રોલ બોર્ડ પાસેથી મળી શકશે. તેમજ એસ.ઈ.આઈ.એ.એ./એસ.ઈ.એસી./ જી.પી.સી.બી.ની વેબસાઈટ પર જોઈ શકાશે.

મુખ્ય ઇજનેર
દીનદયાલ પોર્ટ ટ્રસ્ટ

રોયલ પ્લોટ્સ એલ.એલ.પી.

ROYAL 13

ફો નં. ૪૮, તા. ૨૫/૦૬/૨૦૨૦

નોંધ: આ પ્રોજેક્ટના અંતિમ અગત્યની સહાય છે.

નર્લ
ગો
કિ:

Annexure -II

**Monitoring the implemental Safe guards Ministry of Environment &
Forests
Regional office (WZ), Bhopal.
Monitoring Report (Up to April, 2020)
DATA SHEET**

Sr. No.	Particulars	Reply
1.	Project type: River valley/ Mining/Industry/ thermal/nuclear/Other (specify)	Infrastructure and Miscellaneous Projects + CRZ
2.	Name of the project	Construction of Interchange cum Road over Bridge (ROB) at LC-236 (Kutch Salt Junction) On NH-141 in the State of Gujarat under EPC Mode
3.	Clearance Letter (s). OM no and date	SEIAA/GUJ/EC&CRZ/8(b)/728/2020 dated 19/06/2020
4.	Location a) District (s) b) State (s) c) Location/latitude/longitude	a) Kutch b) Gujarat c) Longitude 70°13"E and Latitude 23°01N
5.	Address for Correspondence a) address of Concerned Project Chief Engineer (with pin code & telephone/telex/fax numbers) b) Address of Executive project Engineer/manager/ (with pin code fax numbers)	a) Superintending Engineer (Design) Kandla Port Trust, Administrative Office Building Annex Building, First Floor, Post Box No.50 Gandhidham – 370201 b) Chief Engineer, Deendayal Port Trust, A.O. Building, Annex, Post Box No.-50, Gandhidham-Kutch. Gujarat Pin – 370201

6.	Salient features a) Of the Project	Salient feature of the project		
		Sr. No.	Particulars	Details
		1.	Project Name	Construction Of Interchange Cum Road Over Bridge(ROB) at LC-236 (KUTCH SALT JUNCTION) On NH-141 in the State of Gujarat under EPC Mode
		2.	Activity at the site	Road over Bridge over railway crossings and a barren stretch
		3.	Length of the Stretch	14.892 Kms
		4.	Built-up Area	255148.5 m ²
		5.	Power Requirement & Sources	1500 KVA
		6.	No. of DG Sets	3 DG sets of total capacity of 1500 KVA (3 x 500 KVA)
		7.	Water requirement & Sources	Total water Requirement: 75 KLD Source: Tanker supply/Gujarat water supply and sewerage board
		8.	Sewage Treatment & Disposal	The total number of workers i.e. 800 people shall generate around 16 KLD of sewage which shall be treated in septic tanks connected to water recycling chambers. The recycled water hence generated shall be used for greenbelt development and dust suppression
		9.	Solid Waste Generated	120 Kg/day
		10.	Estimated number of Labors	800
		11.	Estimated greenbelt area	25000 m ²

	b) Of the Environmental Management Plan	<table border="1" data-bbox="782 191 1511 264"> <tr> <td data-bbox="782 191 862 264">12.</td> <td data-bbox="862 191 1089 264">Cost of the project</td> <td data-bbox="1089 191 1511 264">Rs. 232.62 Crores</td> </tr> </table> <ul style="list-style-type: none"> • Commitment & Policy: The management will strive to provide and implement the Environmental Management Plan that incorporates all issues related to air, water, land and noise. • Planning: This includes identification of environmental impacts, legal requirements and setting environmental objectives. <ul style="list-style-type: none"> • Implementation: This comprises of resources available to the developers, accountability of contractors, training of operational staff associated with environmental control facilities and documentation of measures to be taken. • Measurement & Evaluation: This includes monitoring, counteractive actions and record keeping 	12.	Cost of the project	Rs. 232.62 Crores
12.	Cost of the project	Rs. 232.62 Crores			
7.	Production Details during compliance period and (or) during the previous financial year	Not applicable			
8.	Breakup of the project area a) Submergence area: forest & non-forest b) Others	Length of the Stretch: 14.89 kms Build up Area: 255148.5 m ² No forest land is involved in the project			
9.	Breakup of the project affected population with enumeration of those losing houses/dwelling units only agricultural land & landless laborer/artisen a) SC. ST/Adivasis b) Others (please indicate whether these figures are based on any scientific and systematic survey carried out of only provisional	The habitation and households are near to the proposed project site as the area already falls under the property of port. The villages fall in the 2-10 km. range from the proposed site and hence there will not be much impact to the people.			

	figures, if a survey is carried out give details and years of survey).	
10.	<p>Financial details</p> <p>a) Project cost as originally planned and subsequent revised estimates and the year of prices reference</p> <p>b) Allocation made for environmental management plans with item wise and year wise break-up</p> <p>c) Benefit cost ratio/Internal rate of Return and the year of assessment Whether (c) includes the cost of environmental management plans so far.</p> <p>d) Actual expenditure incurred on the project</p> <p>e) Actual expenditure incurred on the environmental management plans so far.</p>	<p>a) Planned Cost: Rs. 232.62 Crores Modified Cost: Rs. 254.92 Crores</p> <p>b) Allocation made for Environmental Management plan: 15 lakhs</p> <p>c) Not applicable</p> <p>d) Rs. 91.77 Crores</p> <p>e) Yet to be done</p>
11.	<p>Forest land requirement</p> <p>a) The status of approval for diversion of forest land for non-forestry use</p> <p>b) The status of clear felling</p> <p>c) The status of compensatory a forestation, if any</p> <p>d) Comments on the viability & sustainability of compensatory a forestation programmed in the light of actual field experience so far</p>	No forest land is involved in the project
12.	The status of clear felling in non-forest areas (such as submergence area of	Not applicable.

	reservoir, approach roads), if any with quantitative information.	
13.	Status of construction a) Date of commencement (Actual and/or planned) b) Date of completion (Actual and/or planned)	(a) Date of start of project 01/10/2020. (b) Schedule date of completion 31/03/2023.
14.	Reasons for the delay if the Project is yet to start	Not applicable
15.	Date of site visited a) The dates on which the project was monitored by the regional office on pervious occasion. if any b) The date site visit for this monitoring report	Not applicable
16.	Details of the correspondence with project authorities for obtaining action plans/information on status of compliance to safeguard other than the routine letters for logistic support for site visit. (The first monitoring report may contain the details of all the letters issued so far but the later reports may cover only the letters issued subsequently.)	a) Superintending Engineer (Design) Kandla Port Trust, Administrative Office Building Annexe Building, First Floor, Post Box No.50 Gandhidham – 370201 b) Chief Engineer, Deendayal Port Trust, A.O. Building, Annex, Post Box No.-50, Gandhidham-Kutch. Gujarat Pin – 370201